

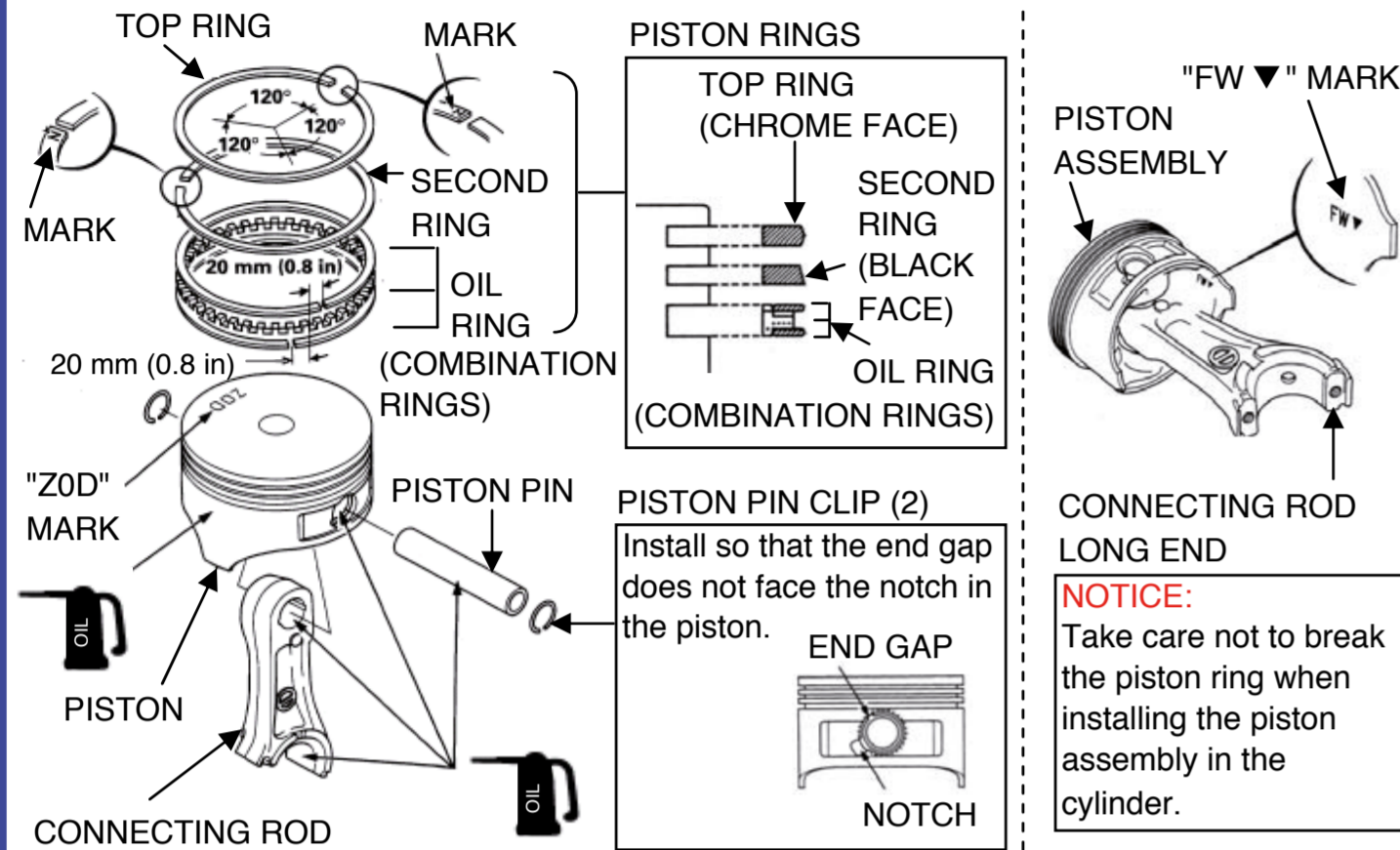

GX100 Engine Assembly Information

HONDA

PISTON



CRANKCASE COVER/GOVERNOR

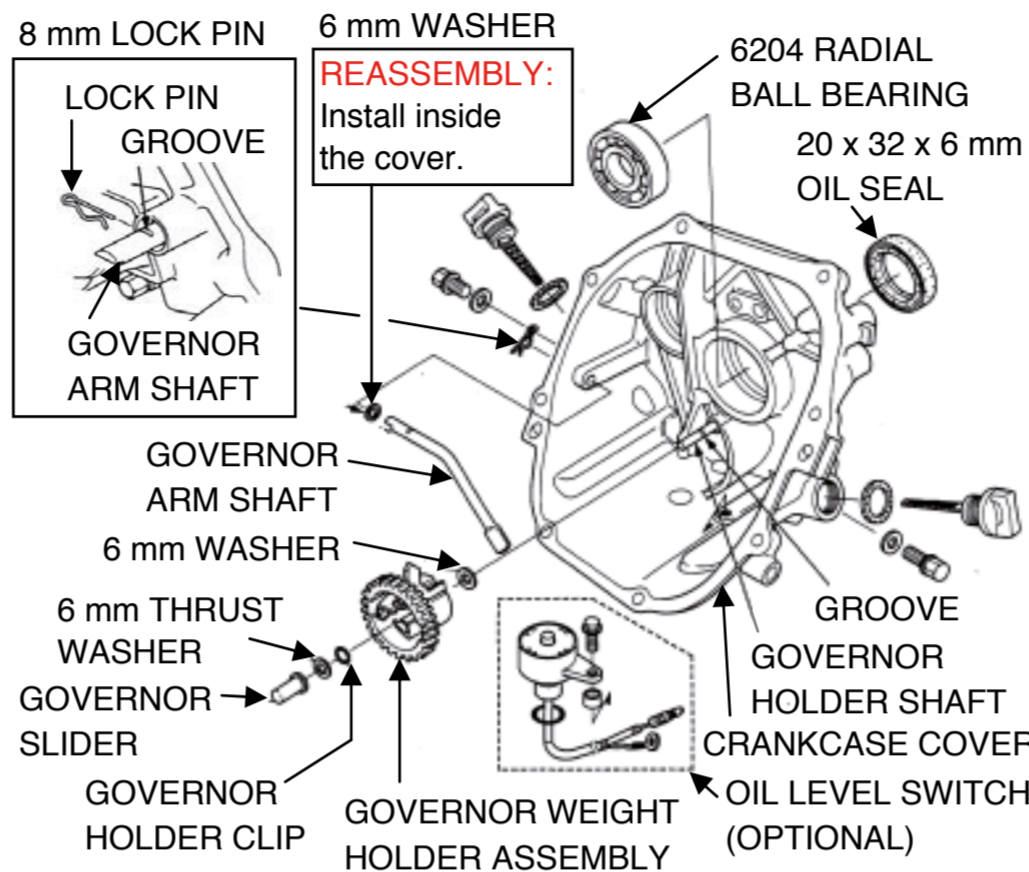

VALVES/FLYWHEEL

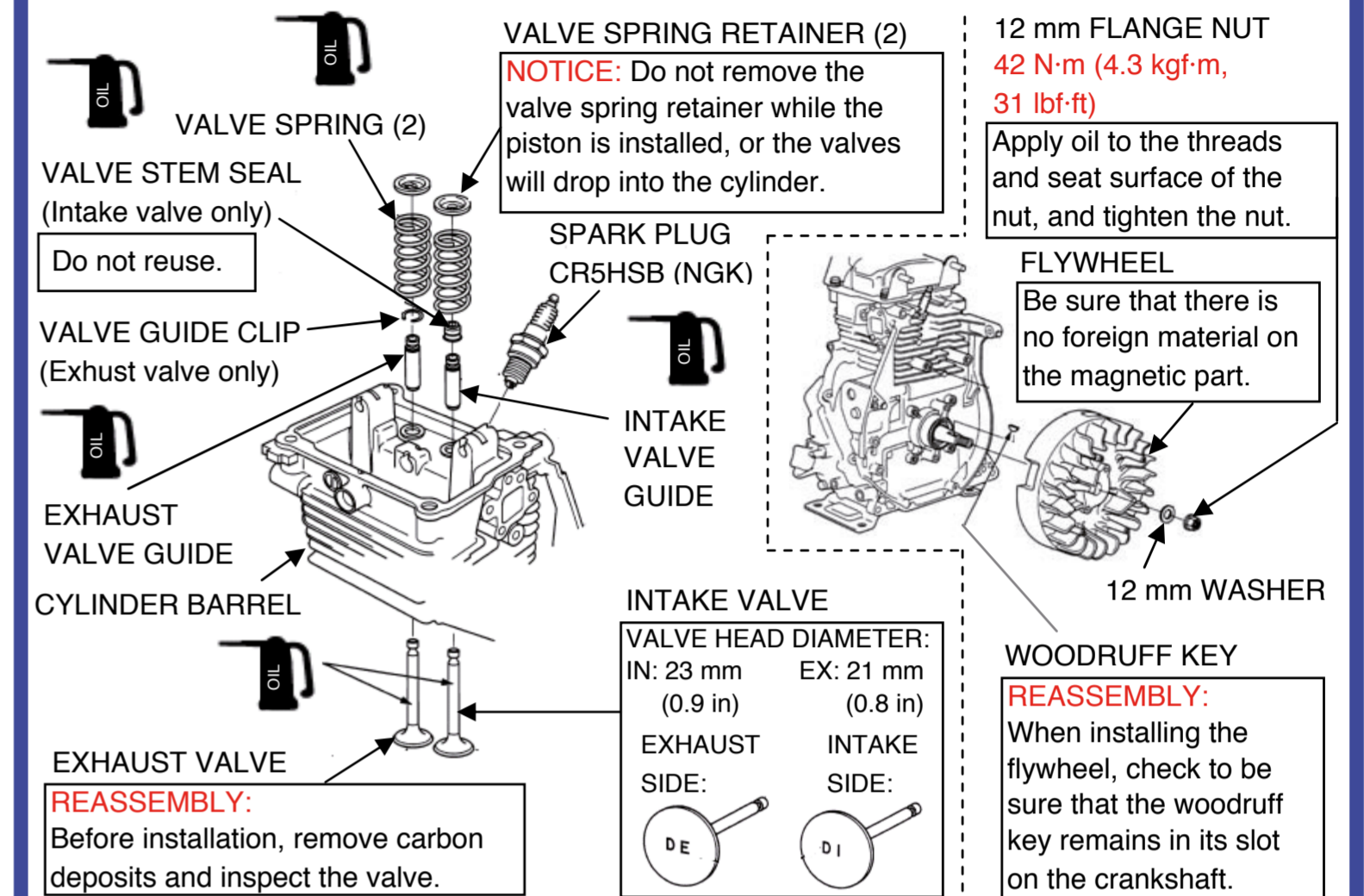

CRANKCASE COVER/CRANKSHAFT/CYLINDER BARREL

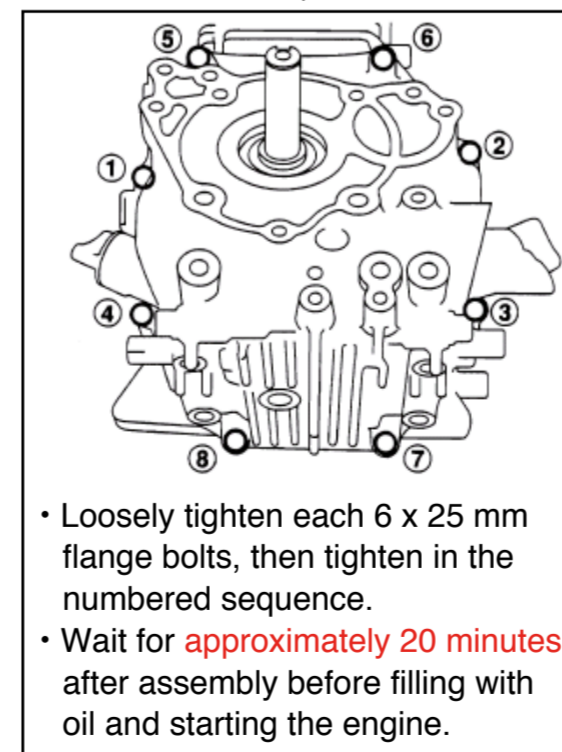
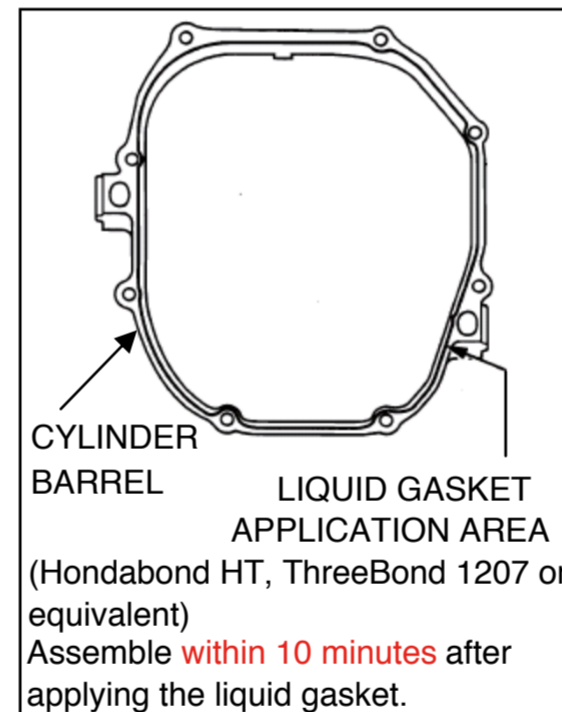
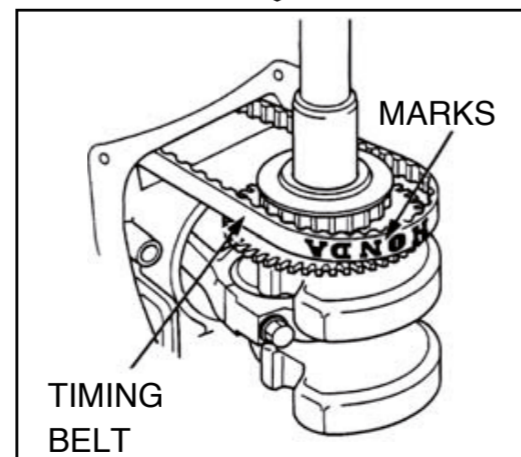
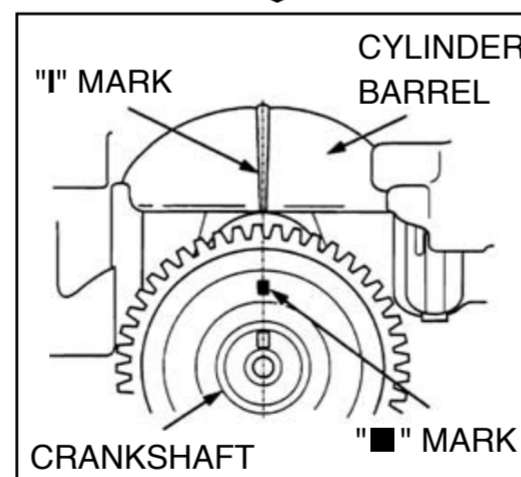
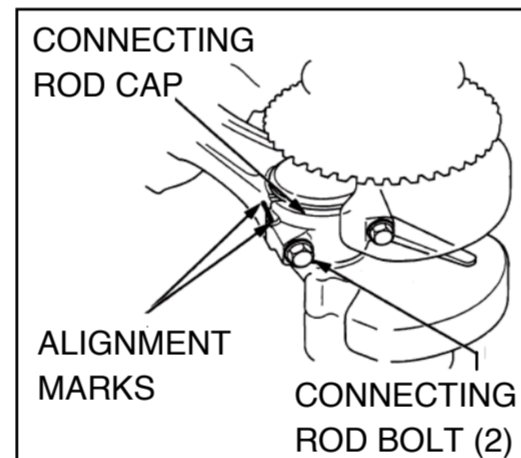
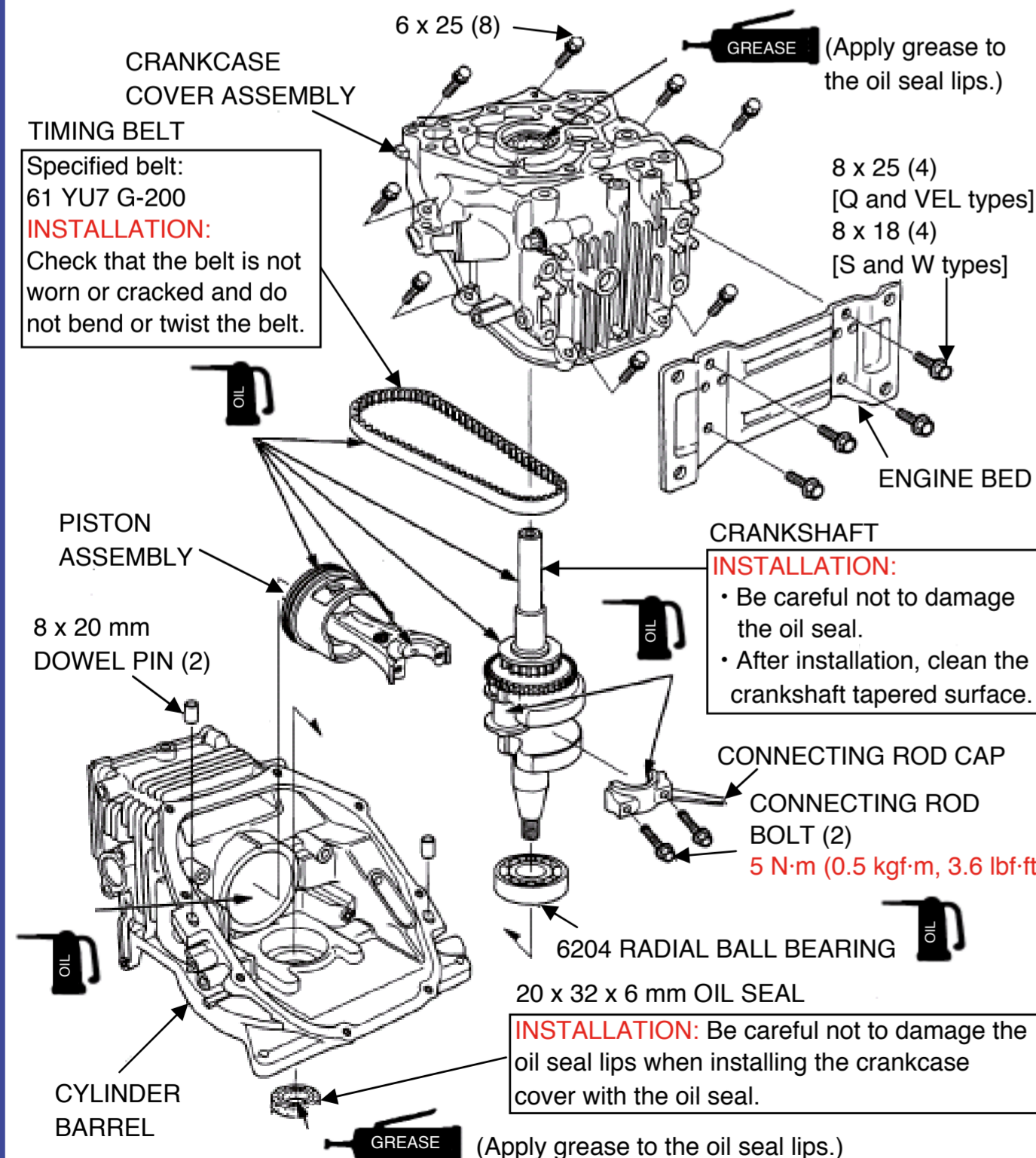

CAM PULLEY/ROCKER ARM/CYLINDER HEAD COVER

