



GX35 Engine Assembly Information

HONDA

CRANKSHAFT/PISTON

PISTON RING

REASSEMBLY:

- Install the second ring with the "•" or "R" mark facing up.
- Do not interchange the top ring and the second ring.
- After assembly, check for smooth movement of the piston rings.
- Stagger the piston ring end gaps 120° apart. Do not align with the piston pin.
- Space the oil ring side rail end gaps at least 10 mm (0.4 in) apart. Coat the oil ring with oil after assembly.

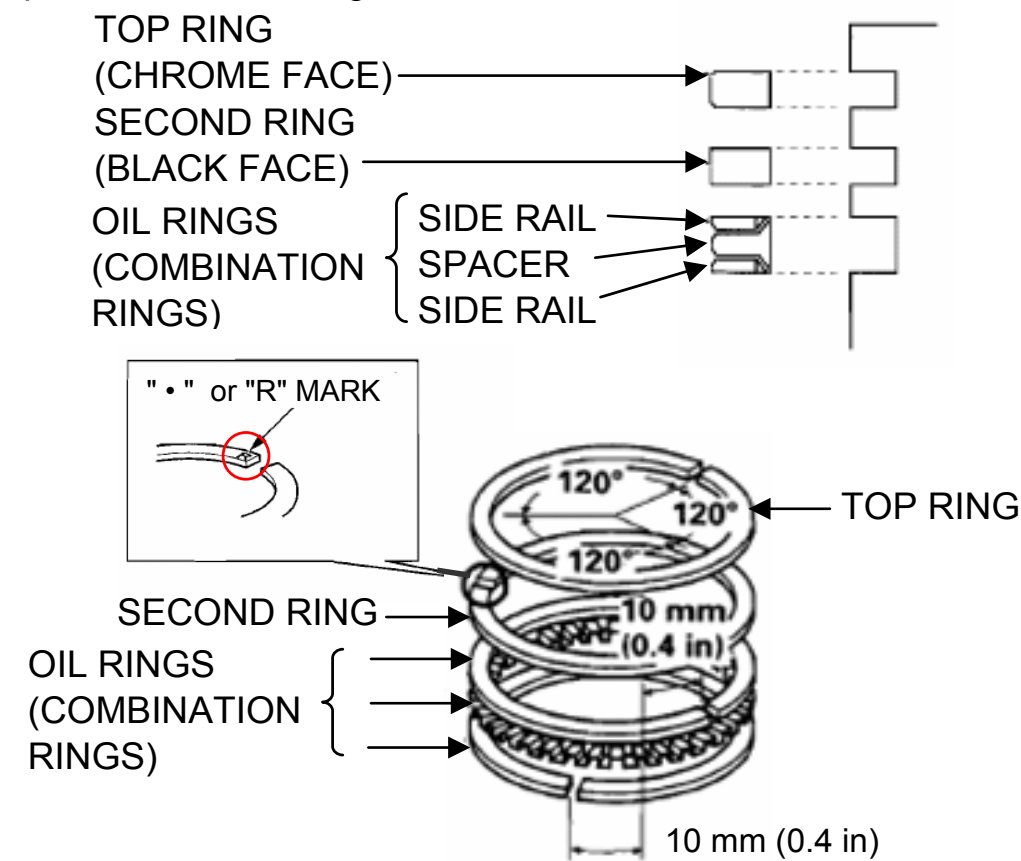

TIMING BELT

INSTALLATION:

- Check that the belt is not worn or cracked and do not bend or twist the belt.

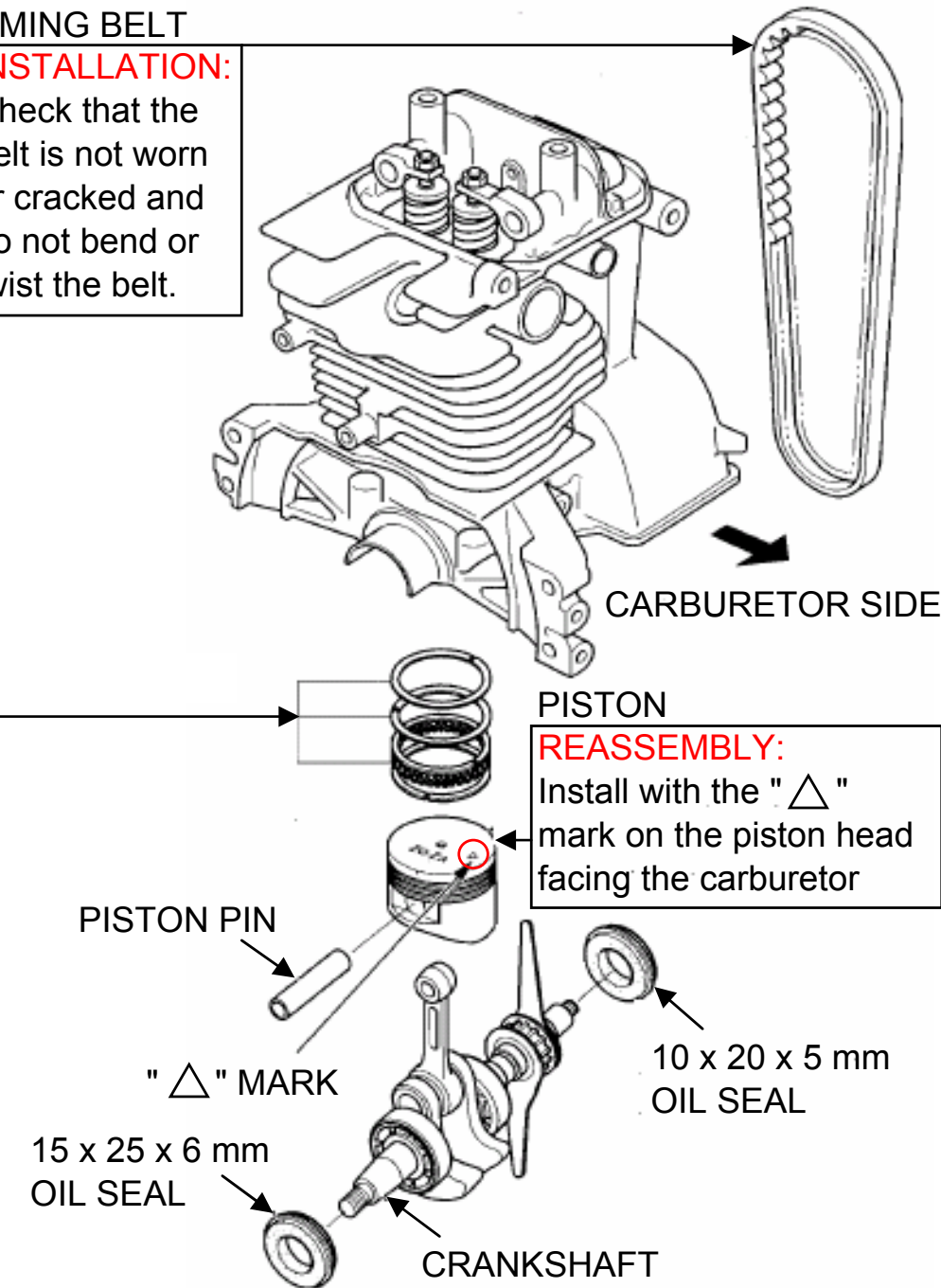

LOWER CRANKCASE

4 x 8 mm SCREW (2)

REASSEMBLY:

- Clean the threads and apply liquid sealant (Loctite® 648, Hondalock 2 or equivalent) to the threads.

OIL OUTLET VALVE PLATE

INSTALLATION:

- Install the oil outlet valve to the oil outlet valve plate by aligning the chamfer and projections.

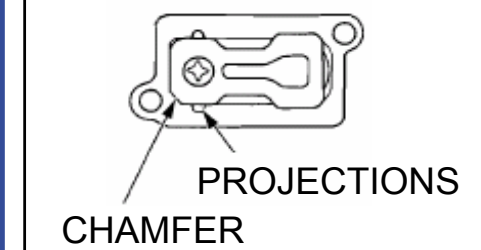

OIL FILLER CAP PACKING
4 x 10 mm SPRING PIN

LOWER CRANKCASE

REASSEMBLY:

- Clean the inside of the crankcase and remove foreign material before reassembly.

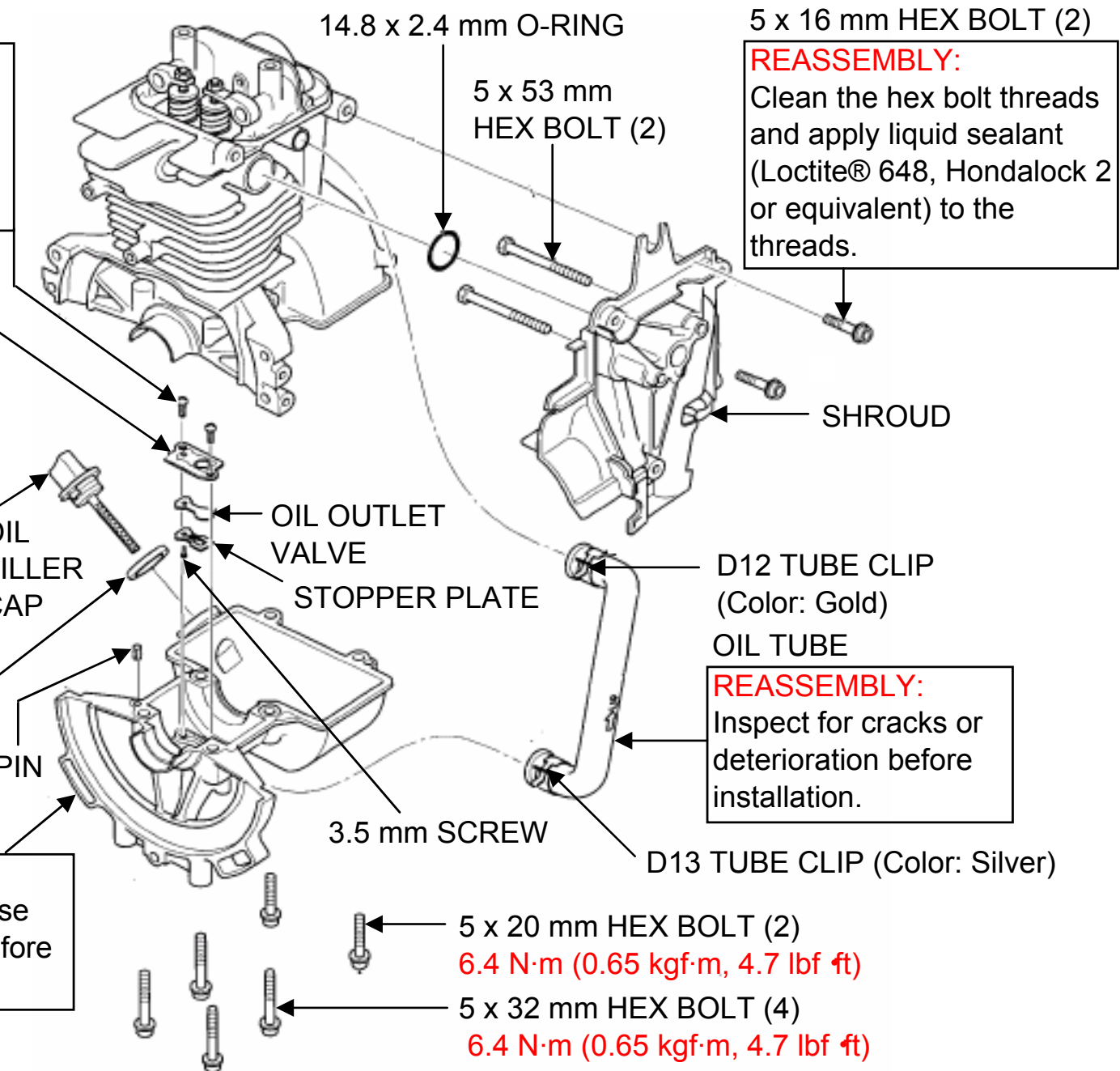

CAM PULLEY/CRANKSHAFT

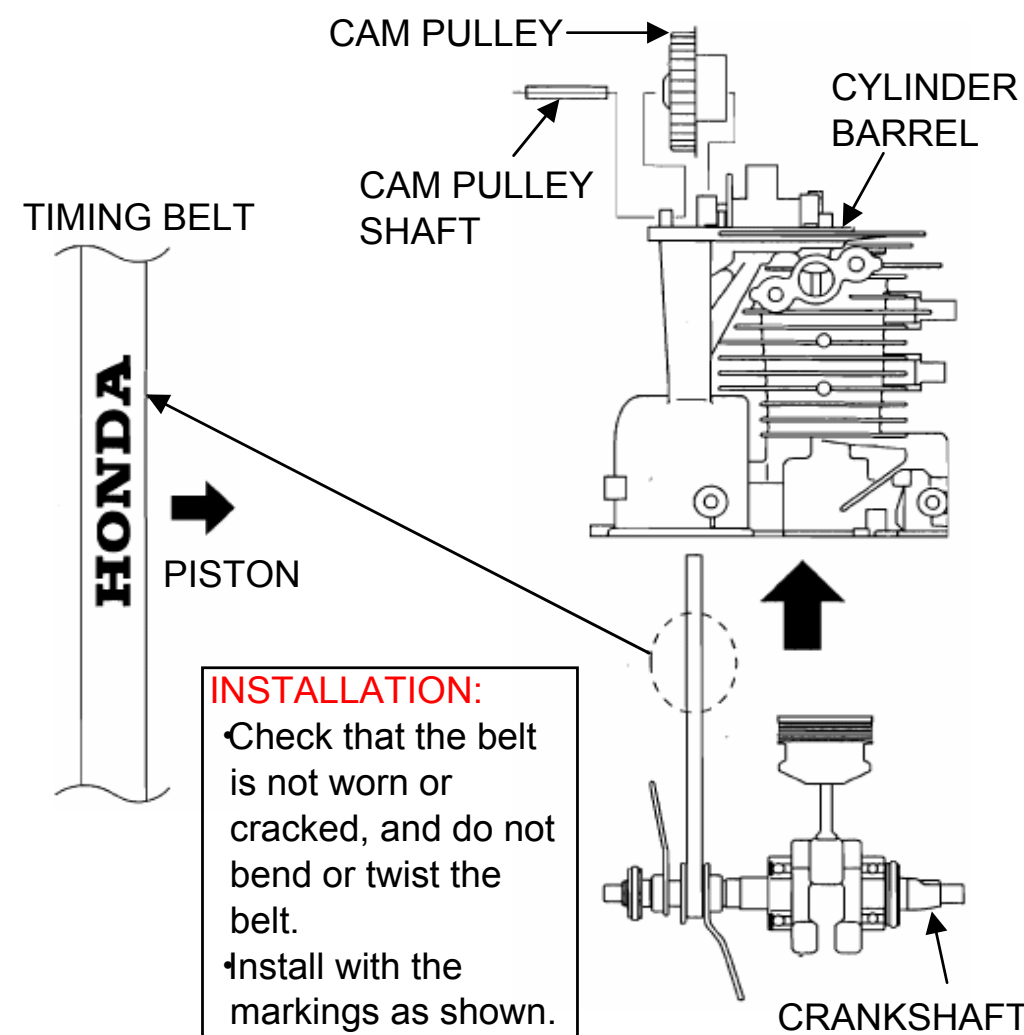
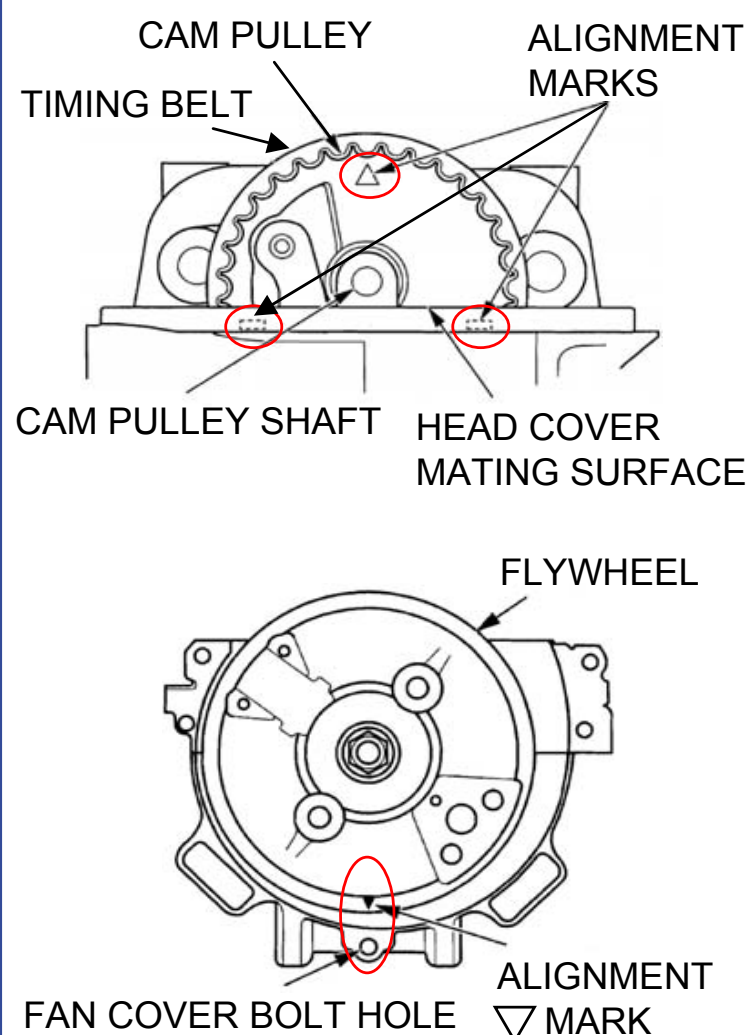

LOWER CRANKCASE/CYLINDER BARREL/VALVES

