

## REGELAAR

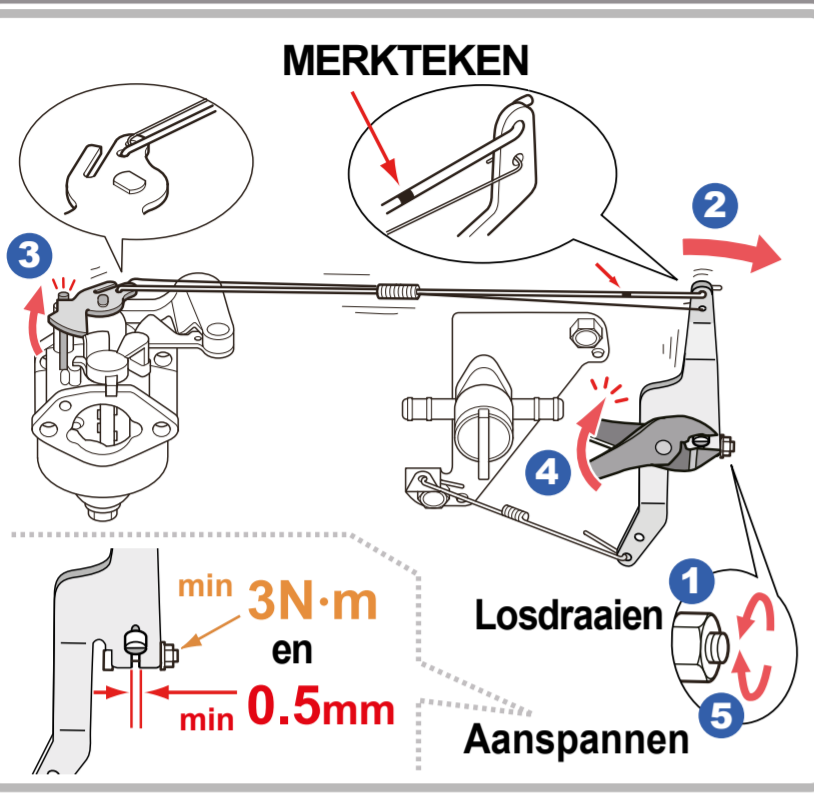

## KLEP SPELING

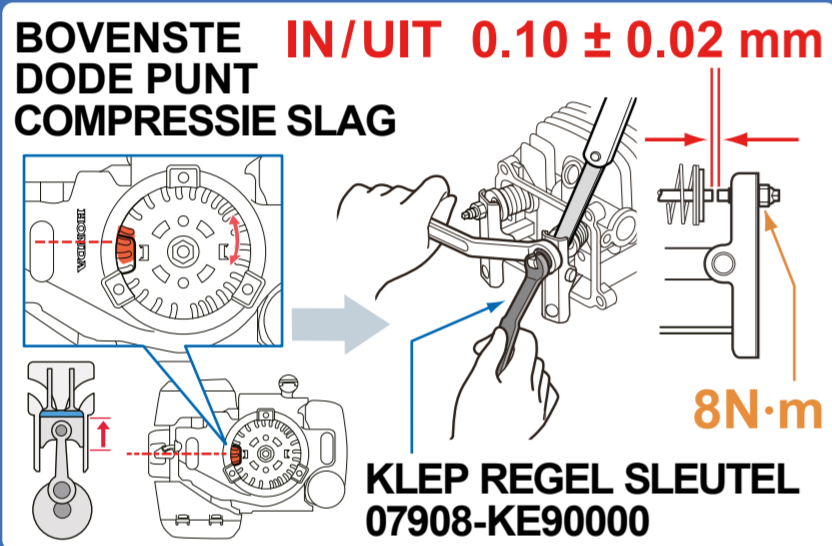

## ONTSTEKING

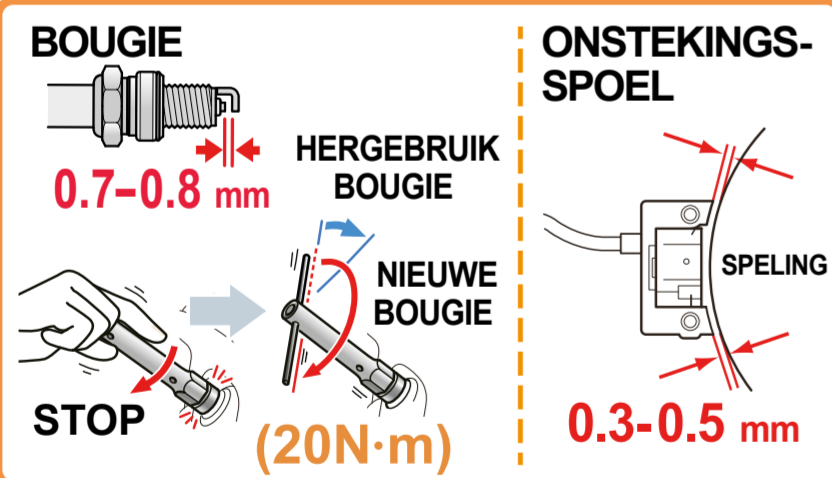

## ZUIGER

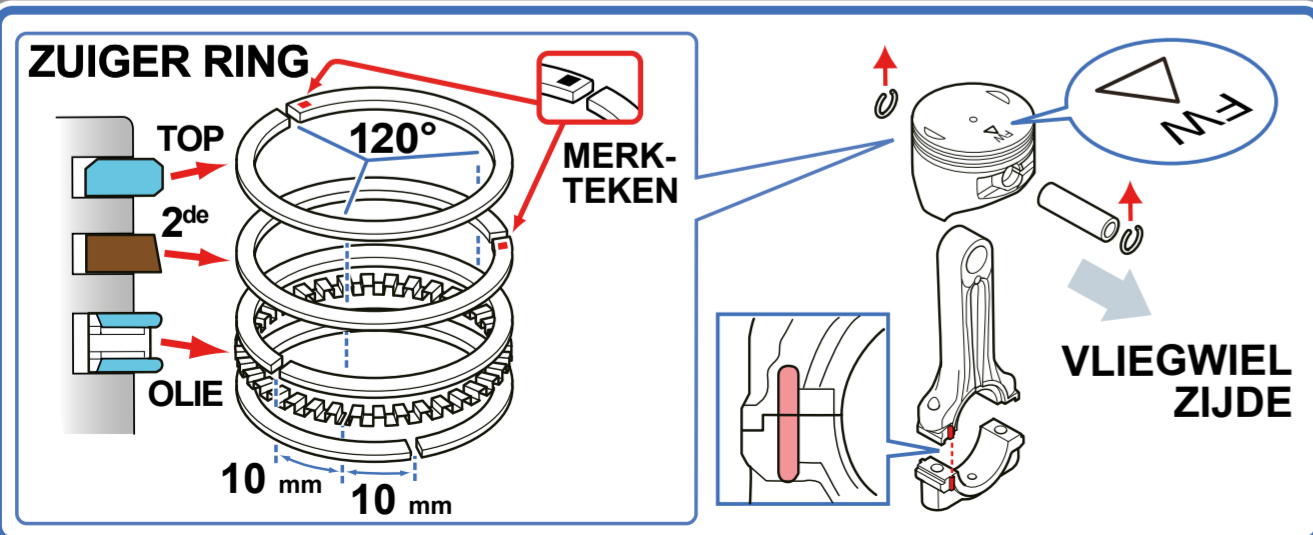

## NOKKENAS

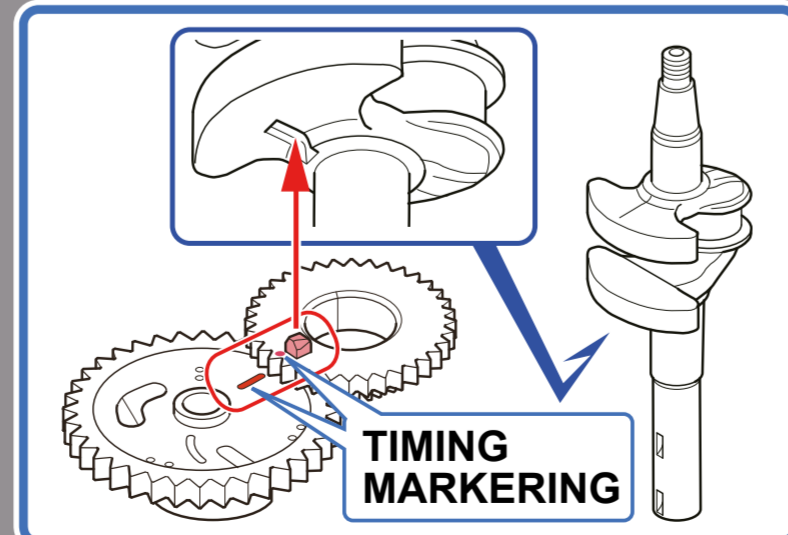

## VLEIOWIEL

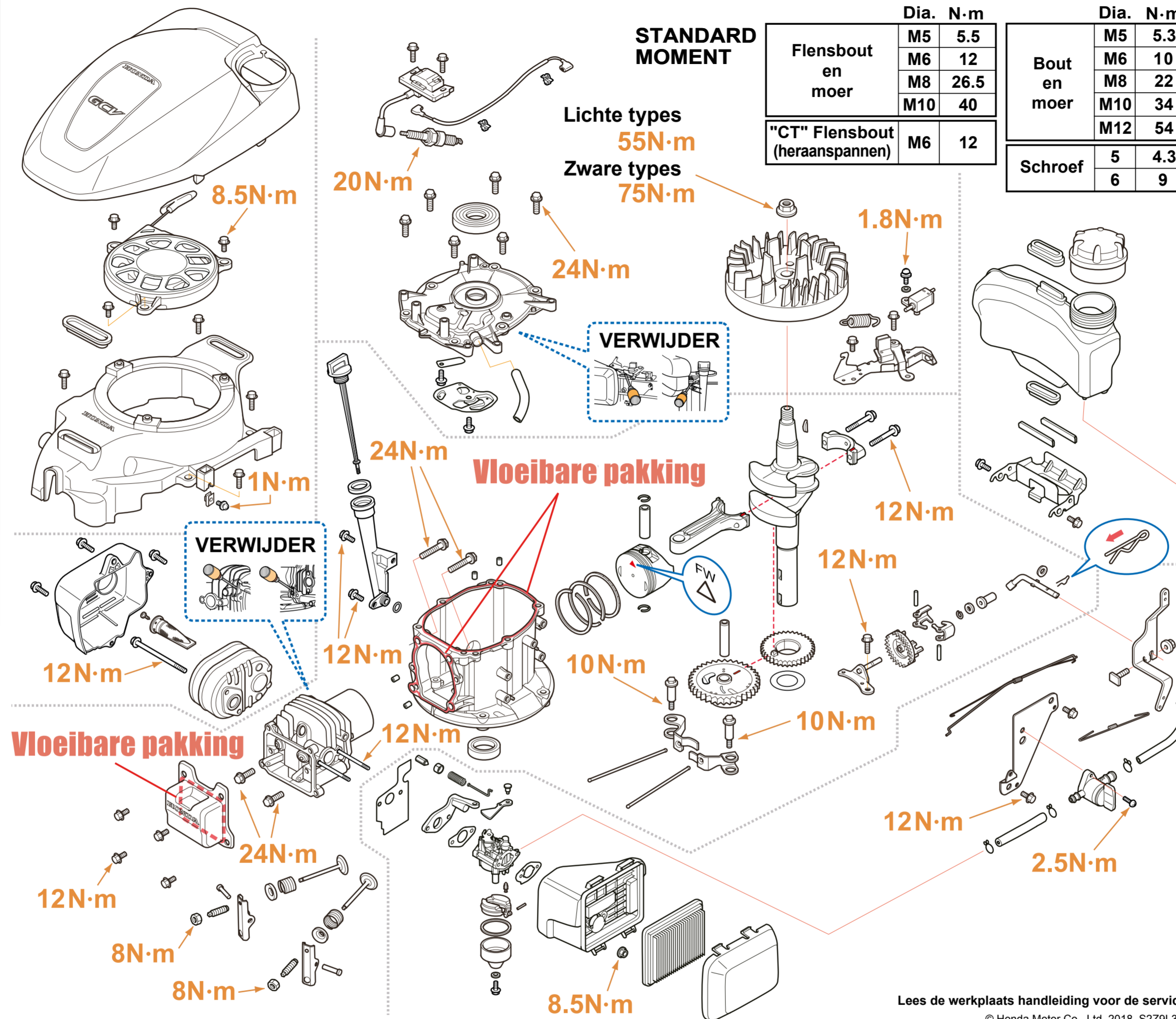
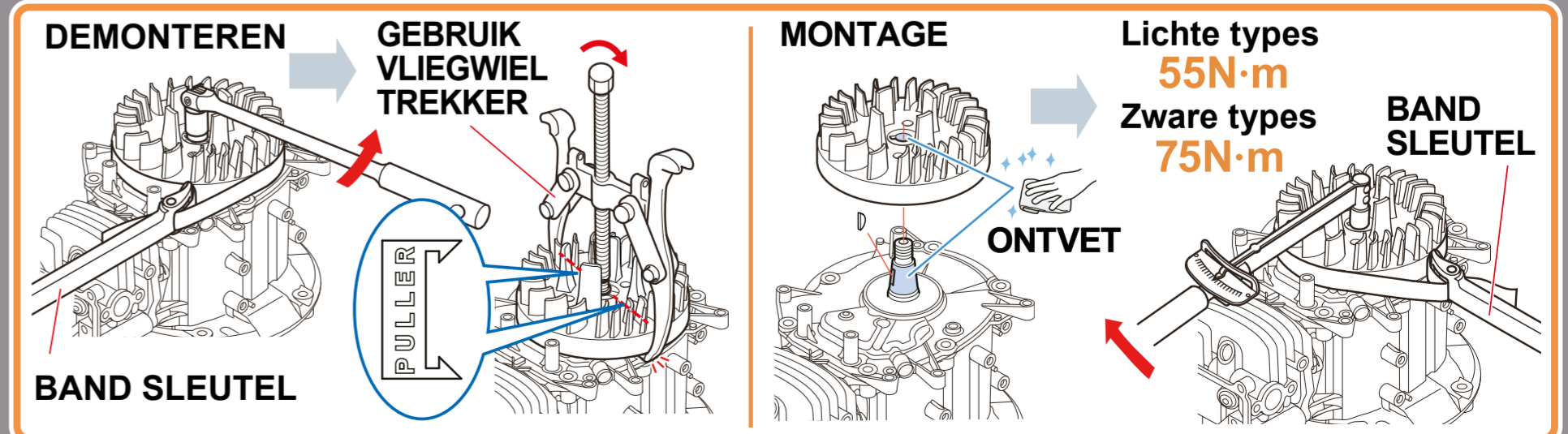

### STANDARD MOMENT

Flensbout en moer	Dia.	N·m
M5	5.5	
M6	12	
M8	26.5	
M10	40	
"CT" Flensbout (heraanstellen)	M6	12

Bout en moer	Dia.	N·m
M5	5.3	
M6	10	
M8	22	
M10	34	
M12	54	

Schroef	Dia.	N·m
5	4.3	
6	9	



## COMPRESSIE CONTROLE

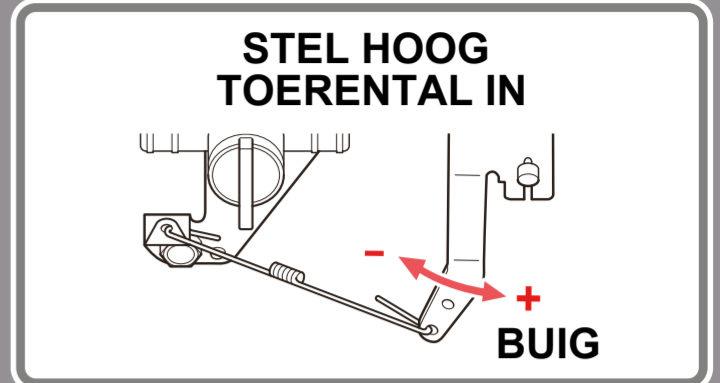

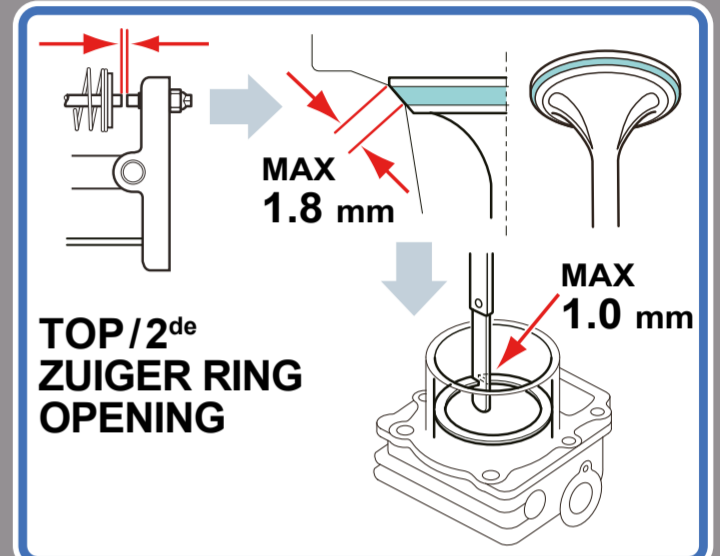
## ONTSTEKINGS CONTROLE

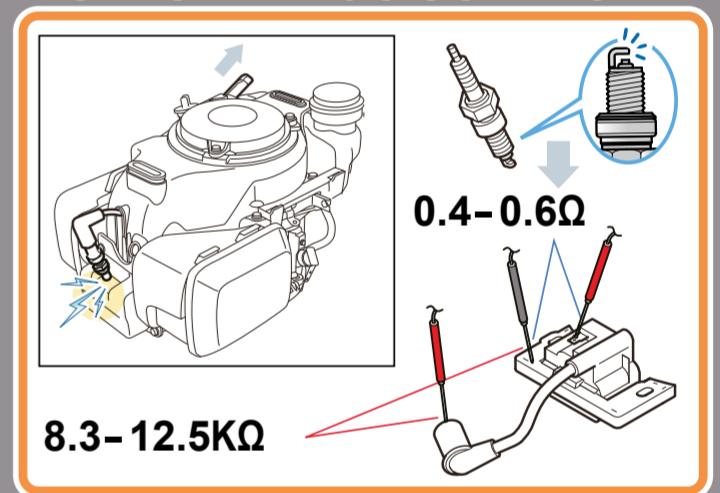

## BRANDSTOF CONTROLE

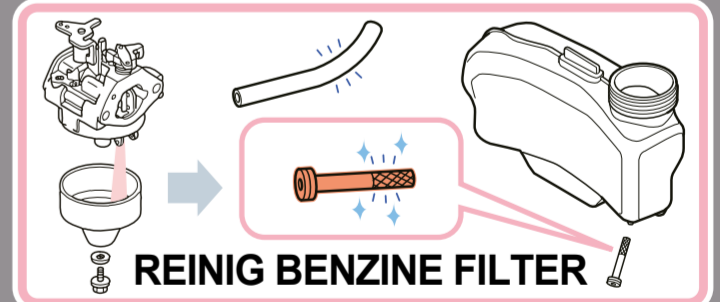

Lees de werkplaats handleiding voor de service.  
© Honda Motor Co., Ltd. 2018 S2Z9L300