

Fuel System Inspection

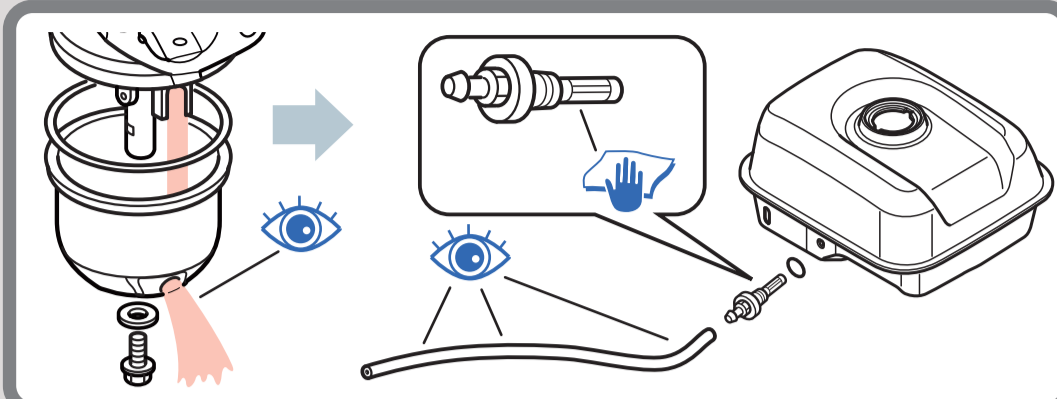

Compression System Inspection

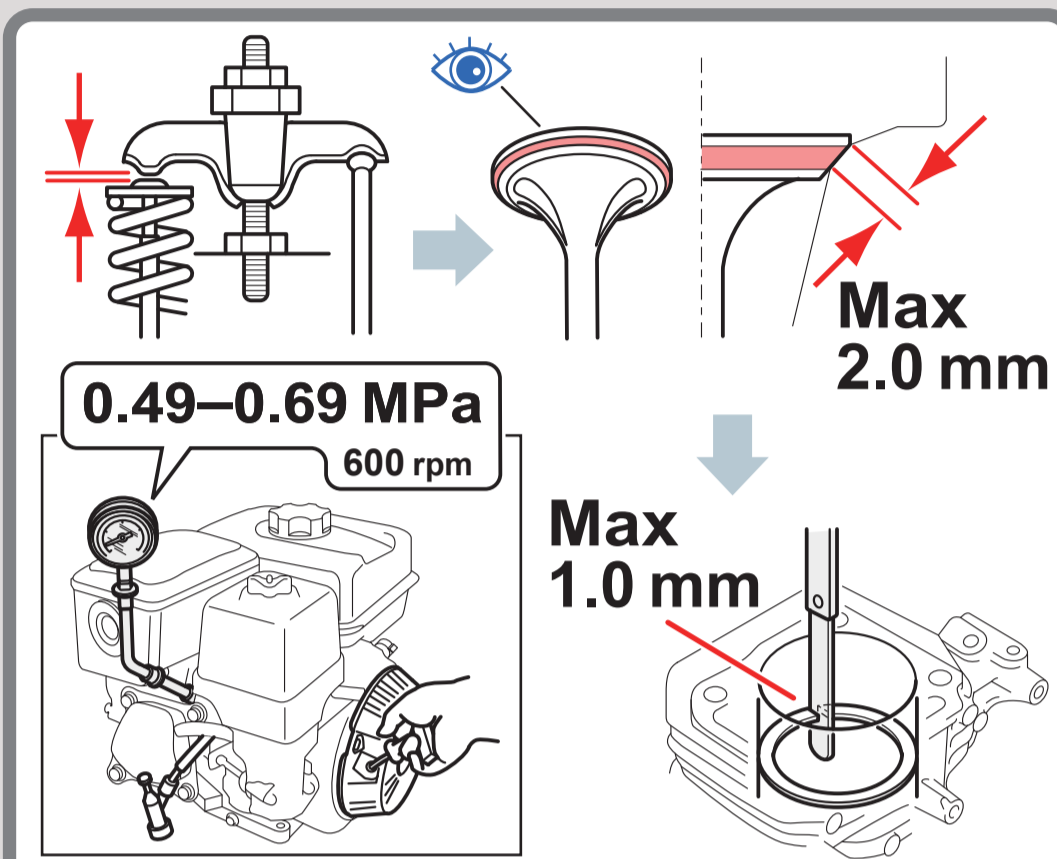

Ignition System Inspection

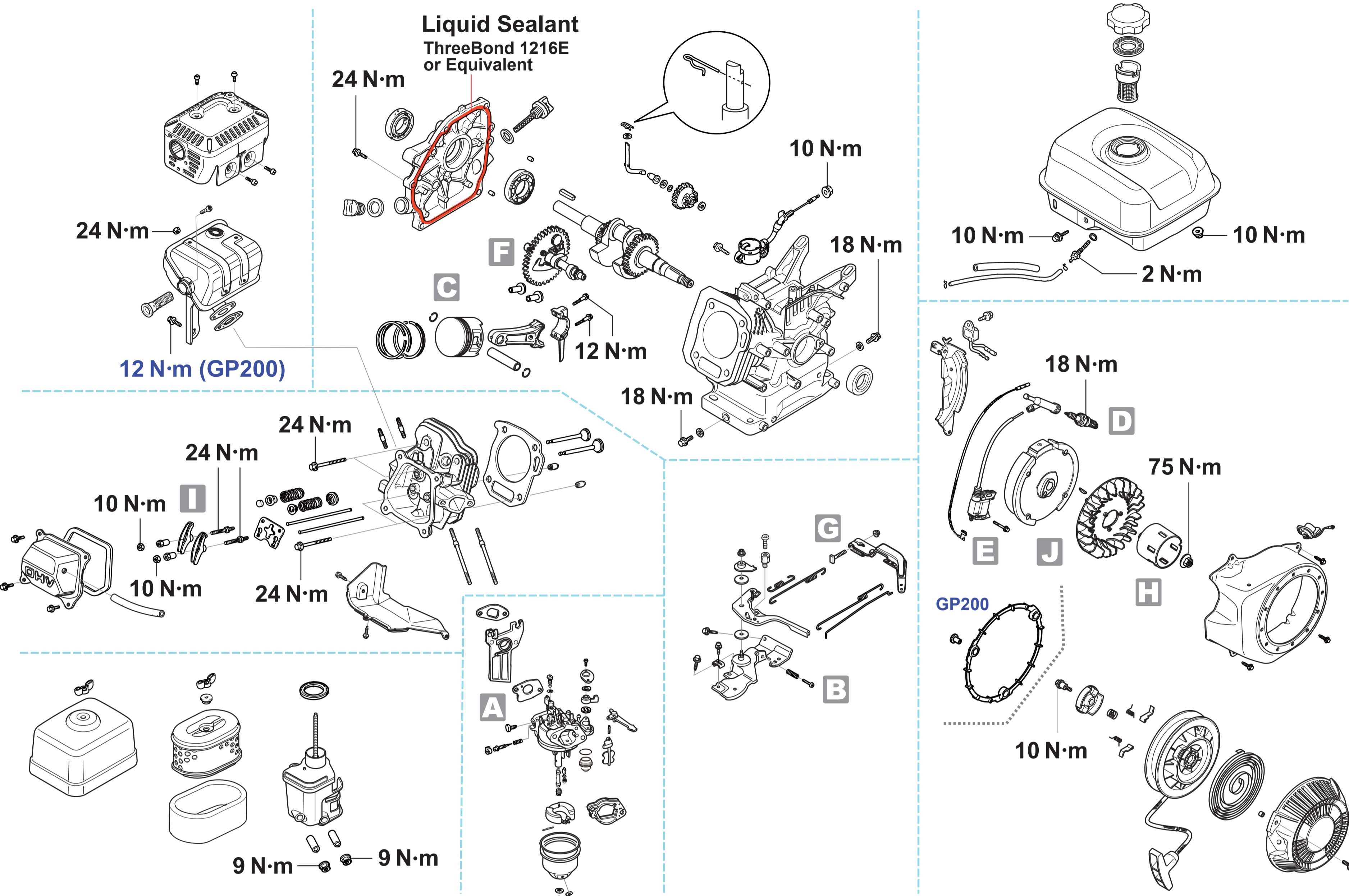
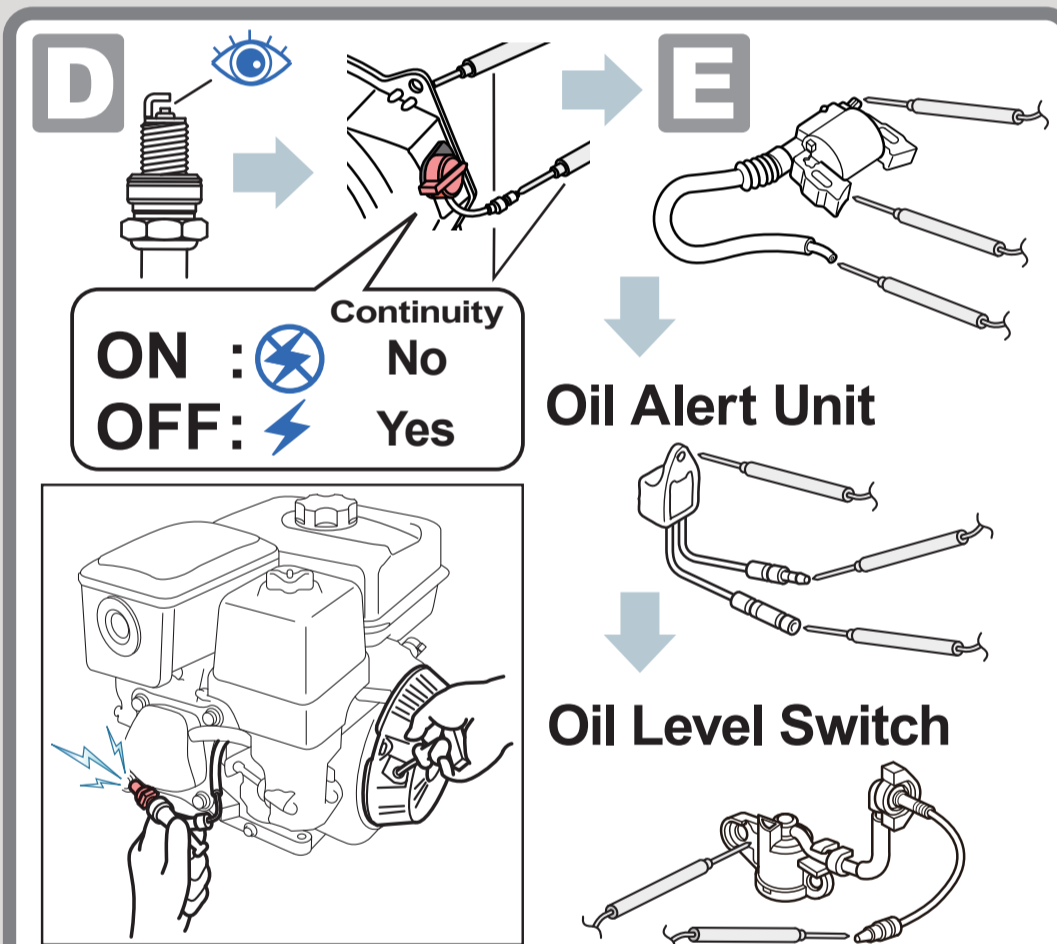

Governor System Assembly

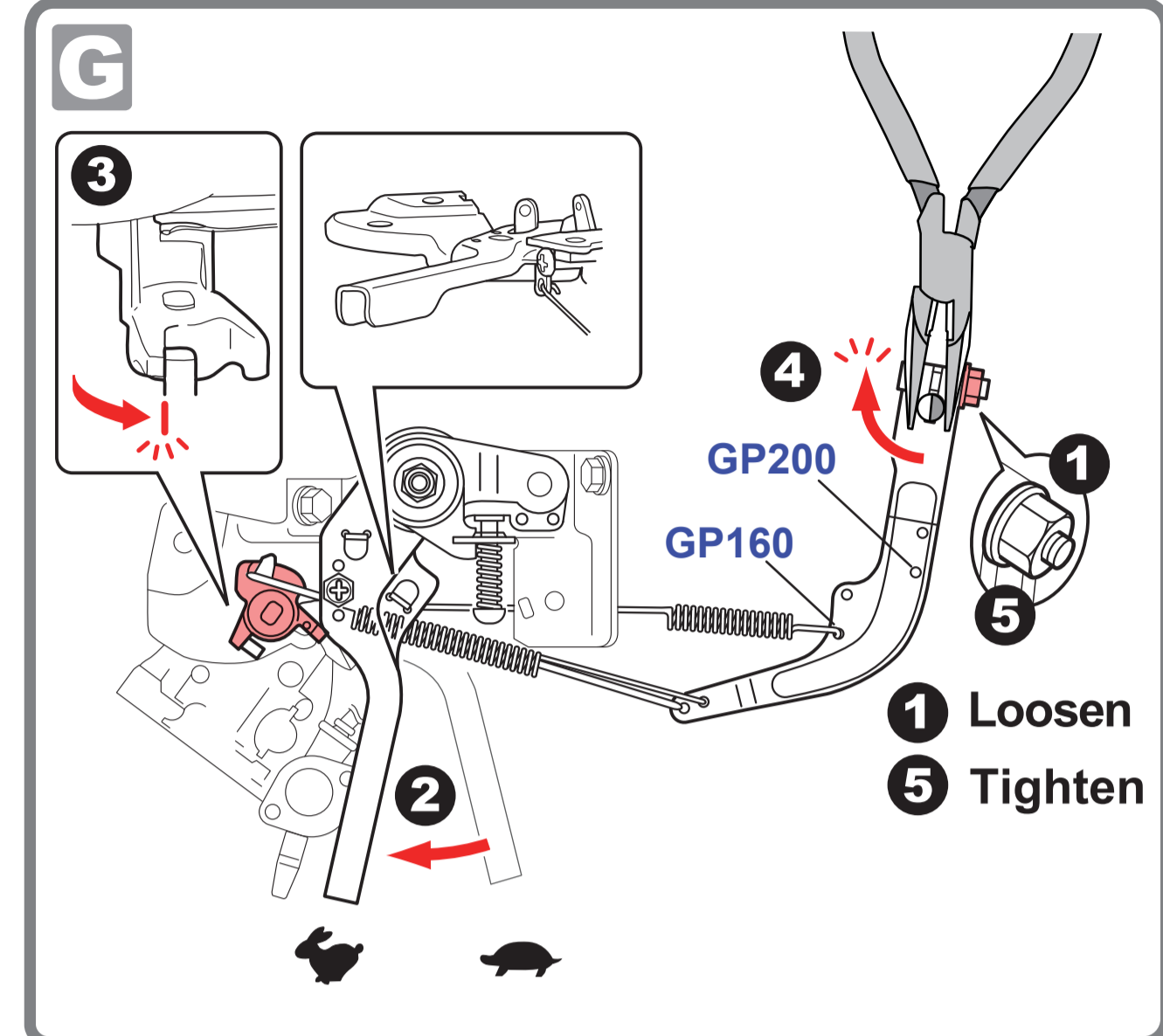

Valve Clearance Adjustment

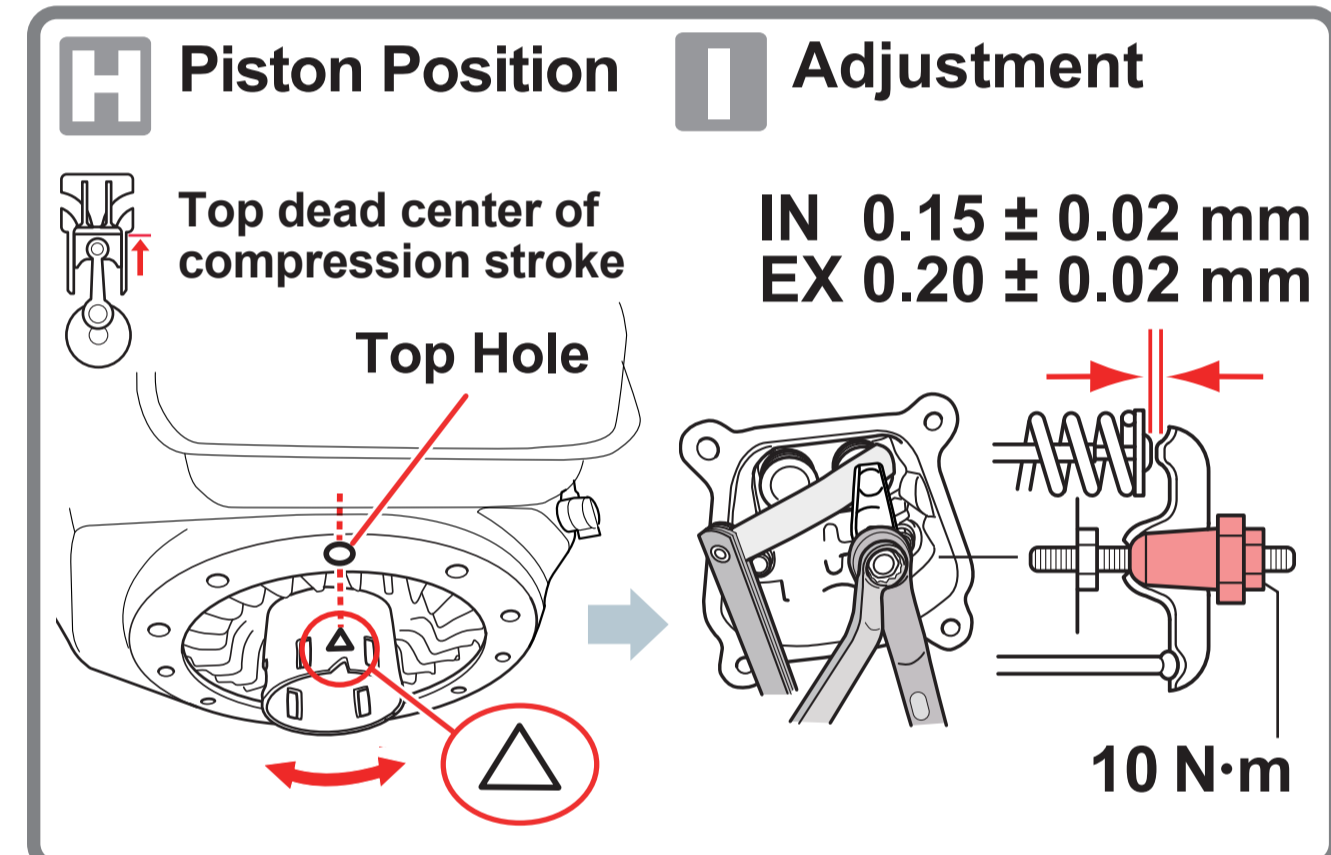

Engine Speed Adjustment

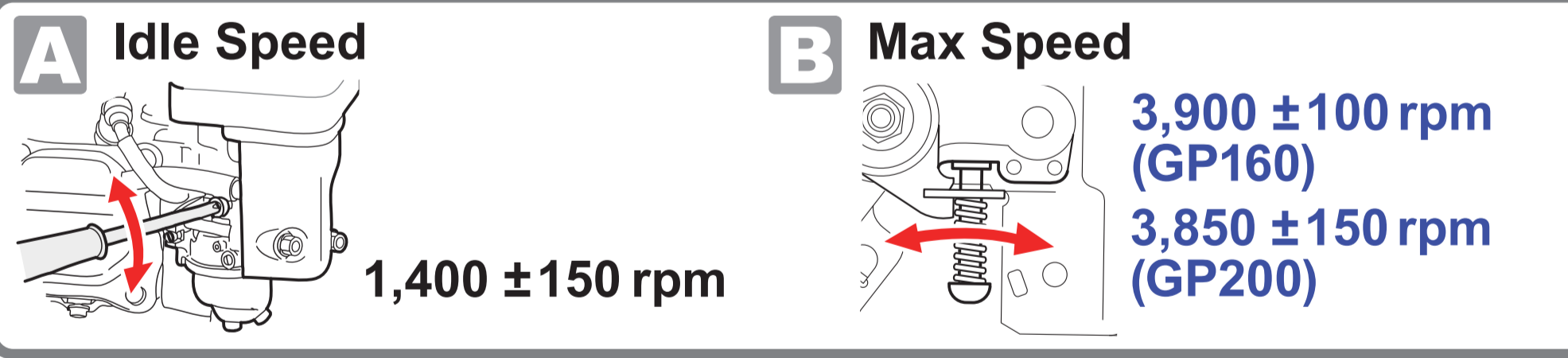

Ignition System Assembly/Adjustment

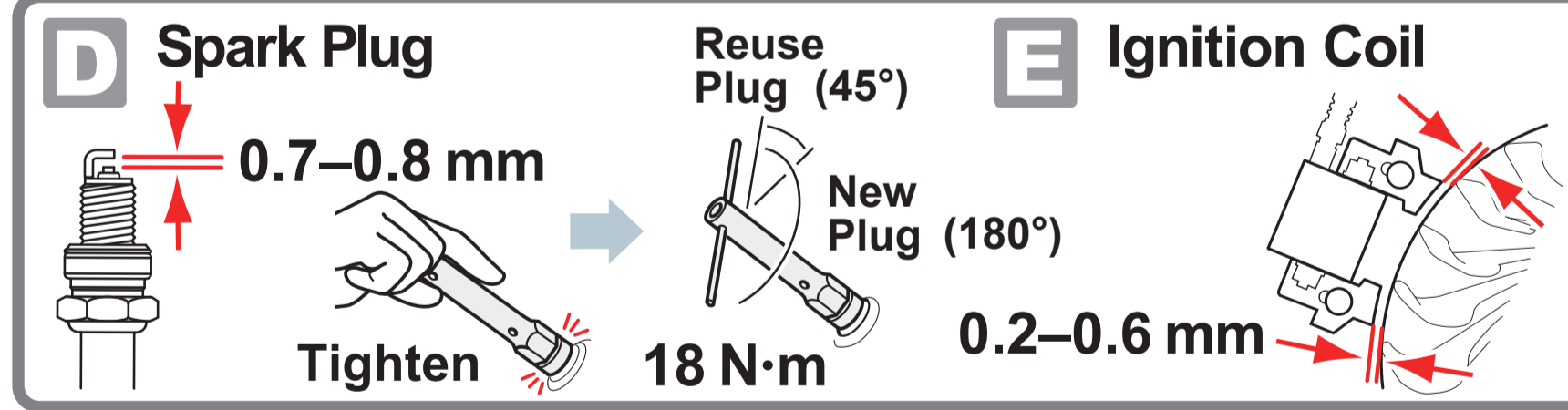

Flywheel Removal/Installation

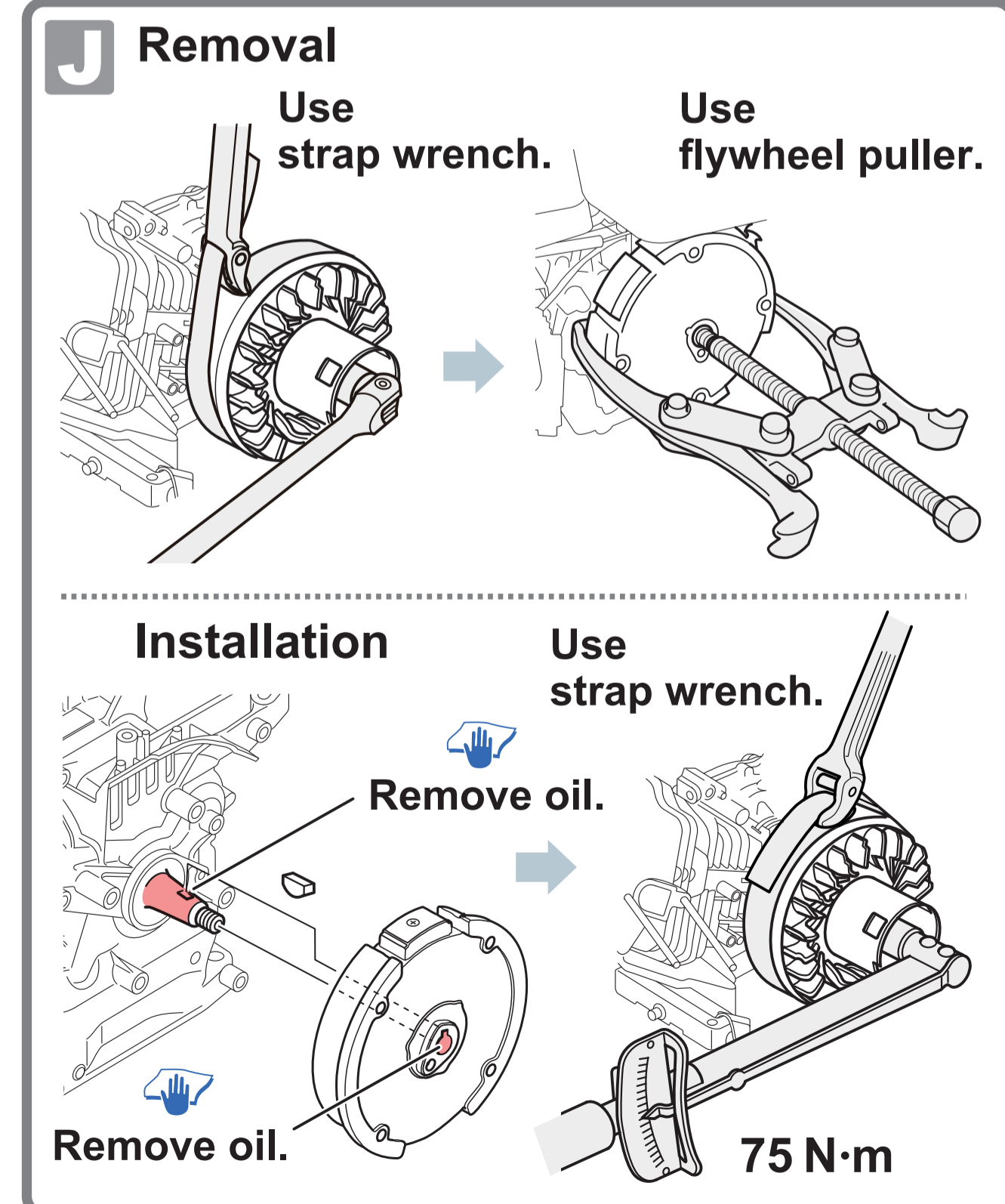

Piston Assembly/Installation

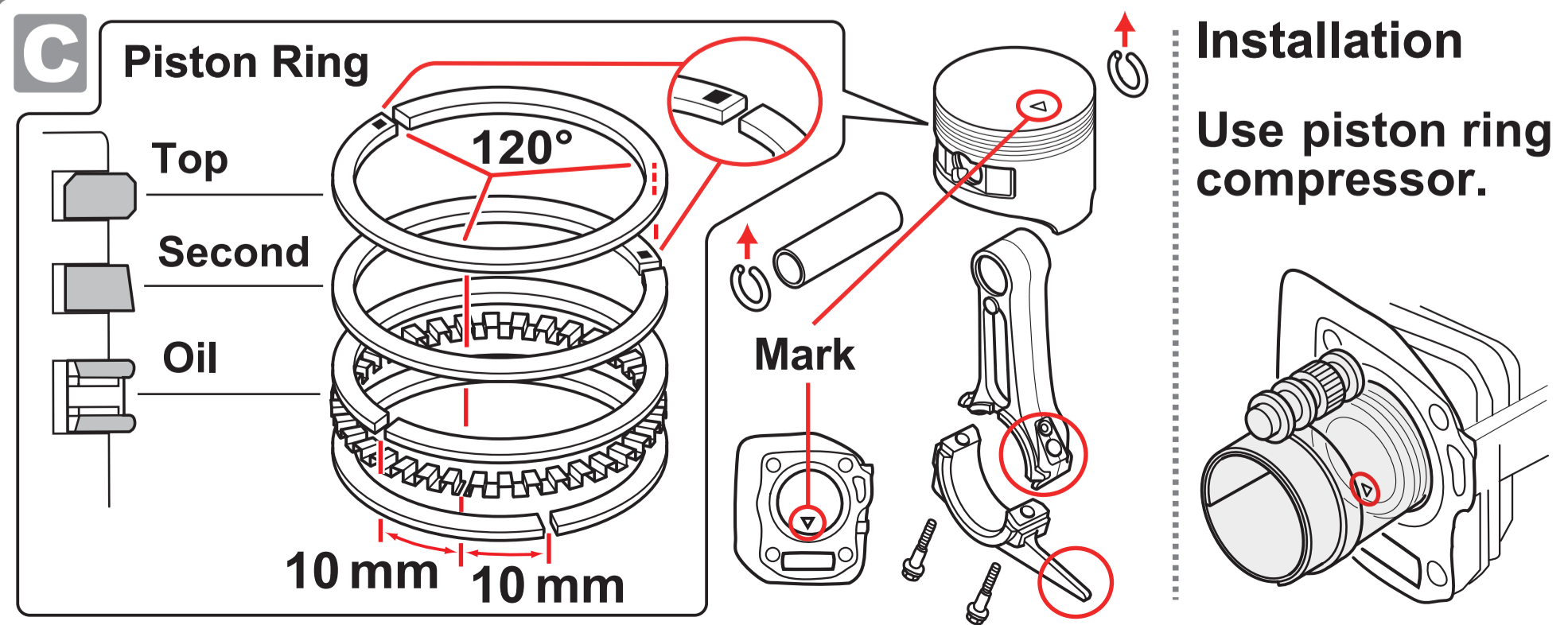

Camshaft Installation

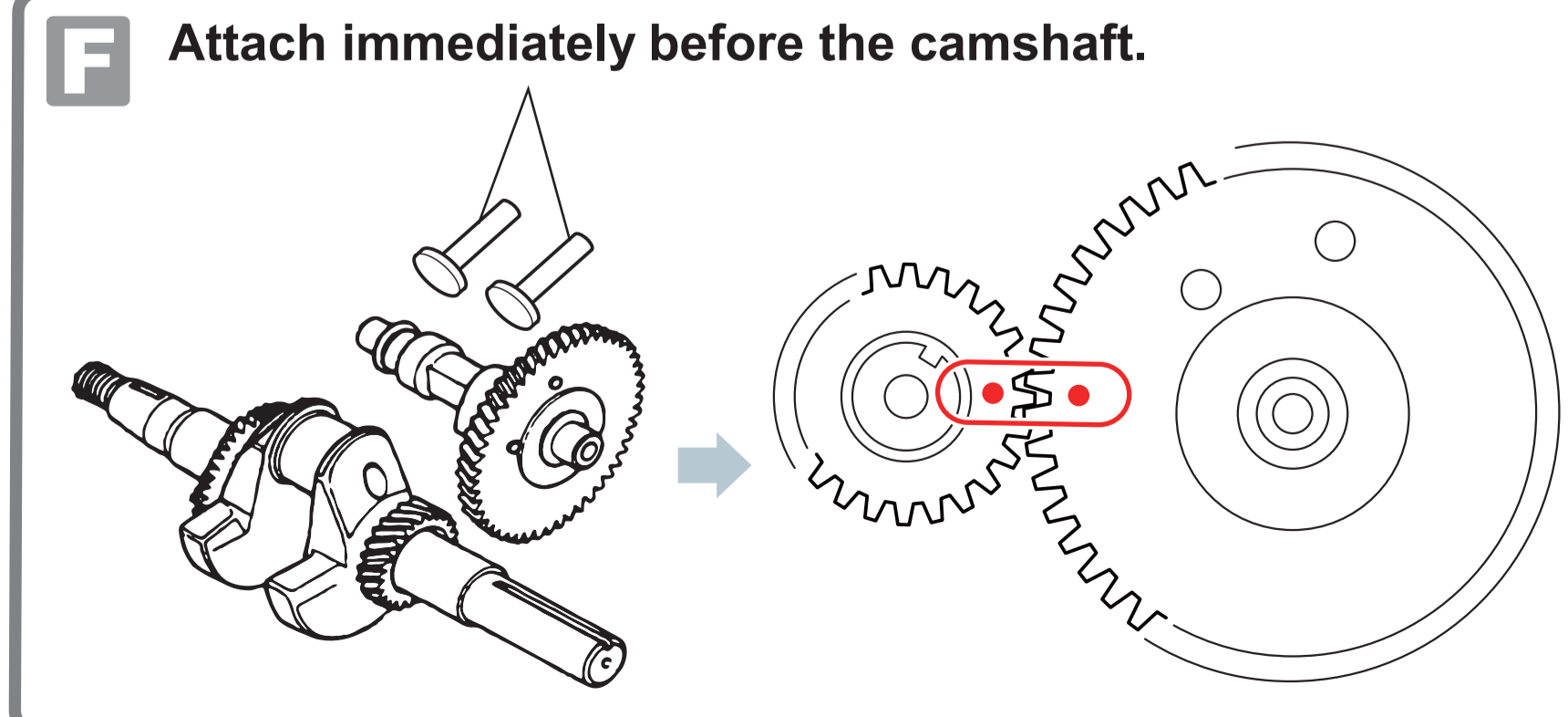

Standard Torque Values

Item	Size	Torque (N·m)
Bolt	M5	5.3
	M6	10
	M8	22
	M10	34
Nut	M12	54
	M5	5.3
	M6	12
Flange Bolt	M6	12
	M8	23
	M10	40
SH Bolt	M6	9.0
	M5	5.4
	M6	12
CT Flange Bolt	M4	2.1
	M5	4.3
Screw	M5	4.3
	M6	9.0

- Fuel
- Compression
- Ignition
- Other