

### Fuel System Inspection

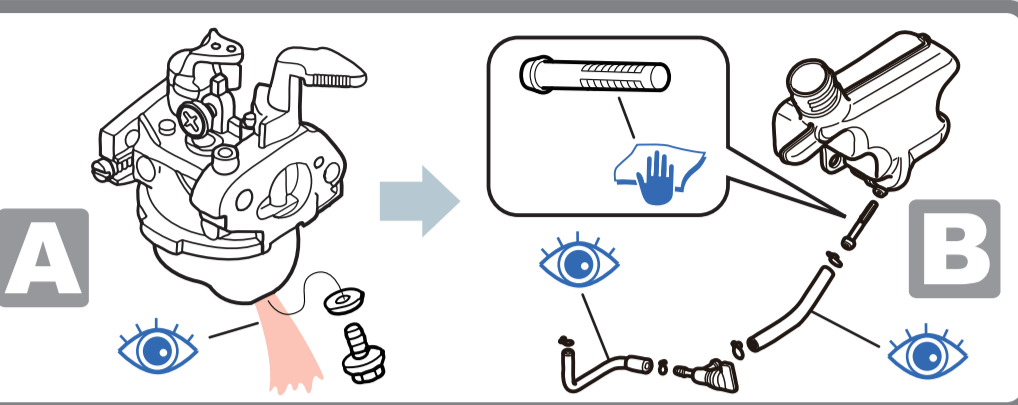

### Compression System Inspection

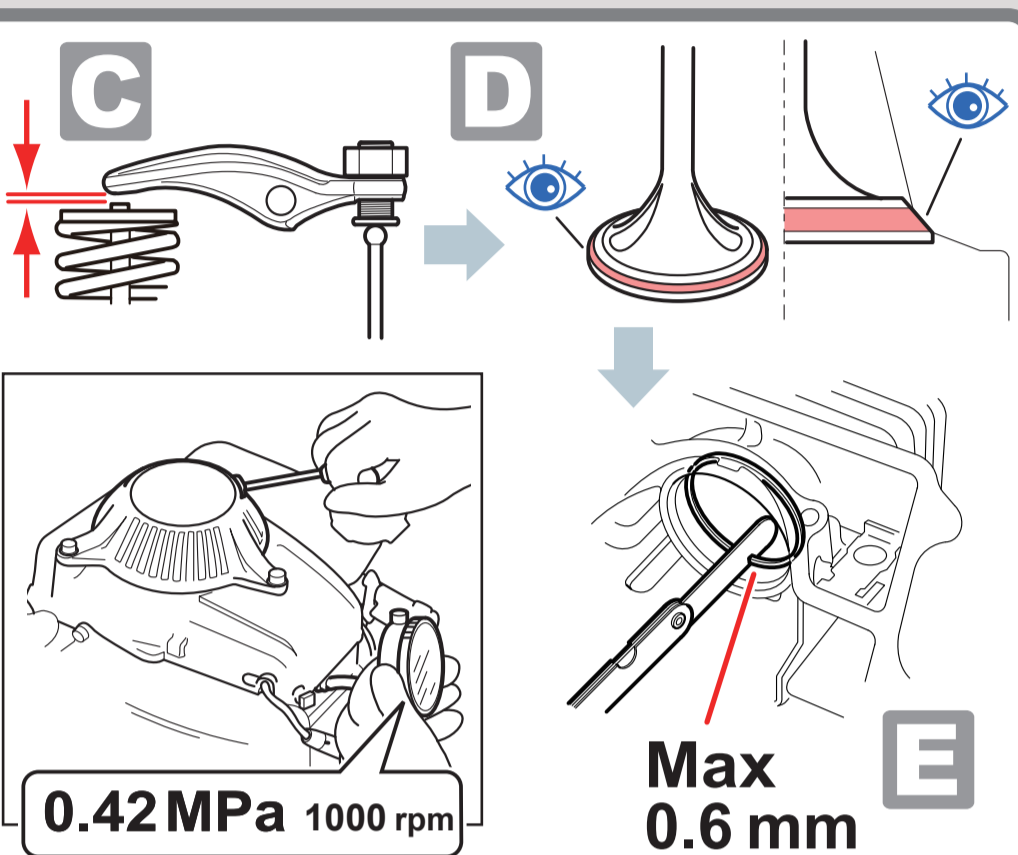

### Ignition System Inspection

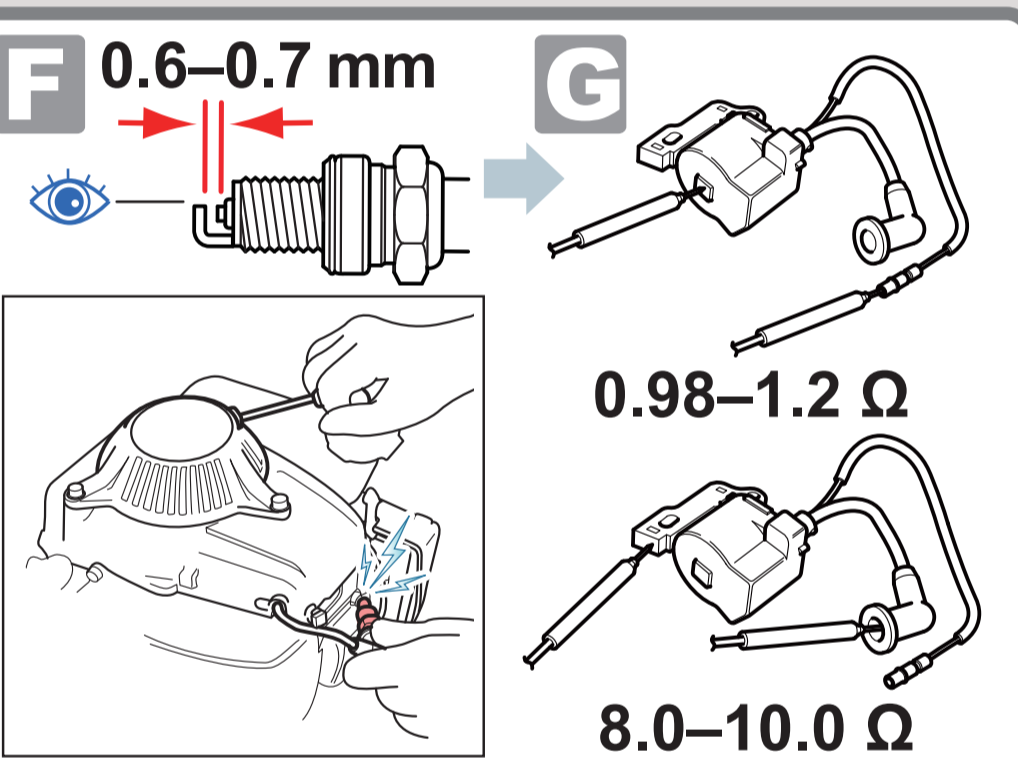

### Engine Speed Adjustment

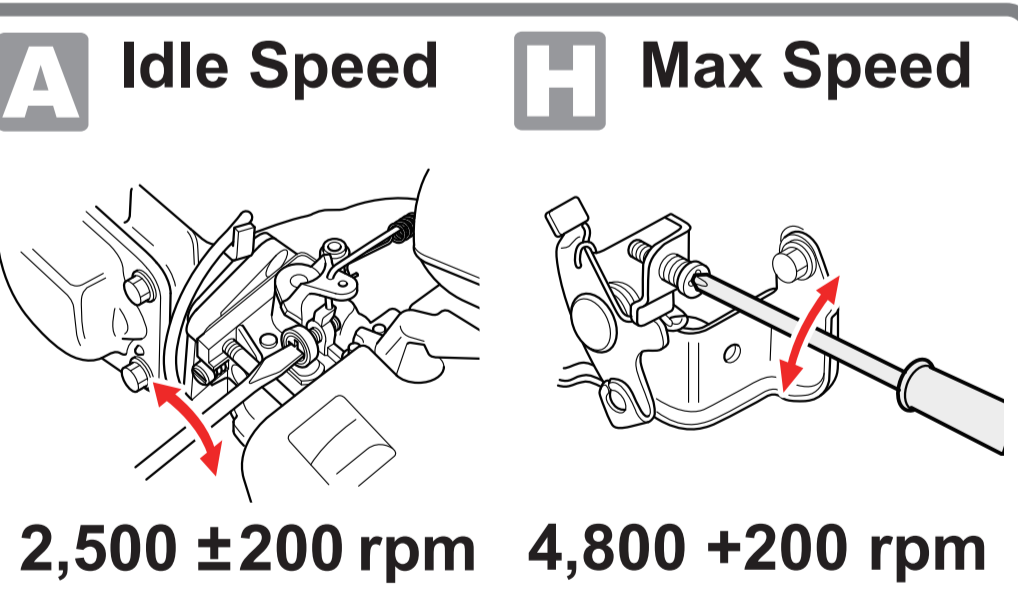

### Ignition System Assembly/Adjustment

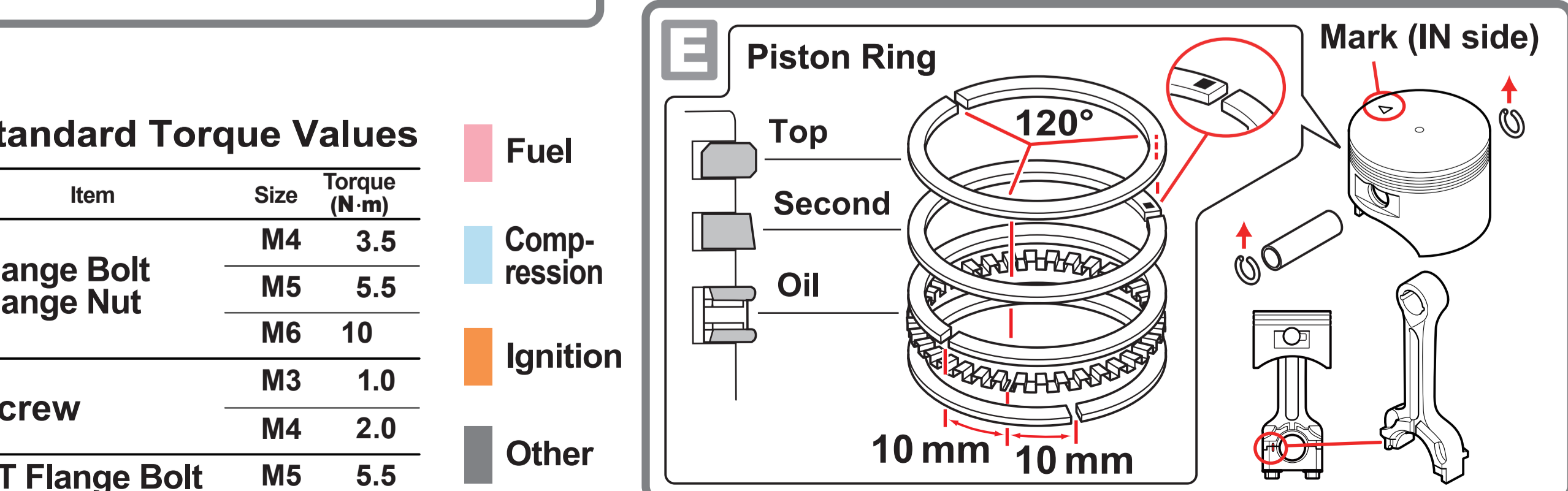

### Standard Torque Values

Item	Size	Torque (N·m)
Flange Bolt Flange Nut	M4	3.5
	M5	5.5
	M6	10
Screw	M3	1.0
	M4	2.0
CT Flange Bolt	M5	5.5

- Fuel
- Compression
- Ignition
- Other

### Piston Assembly/Installation

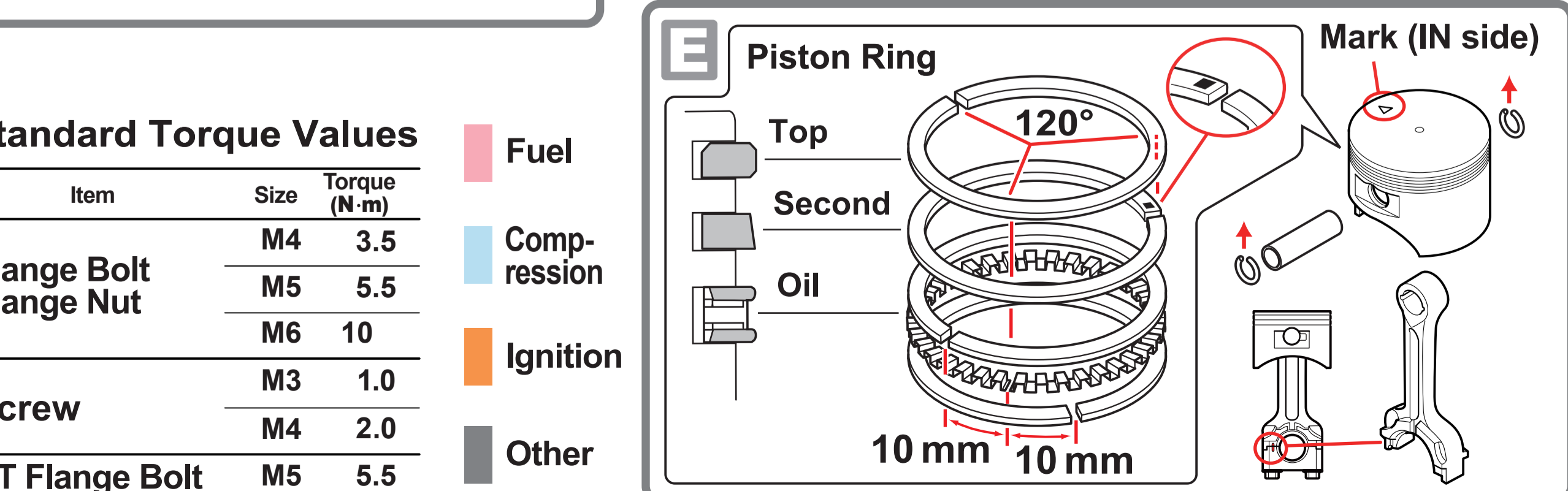

### Camshaft Installation

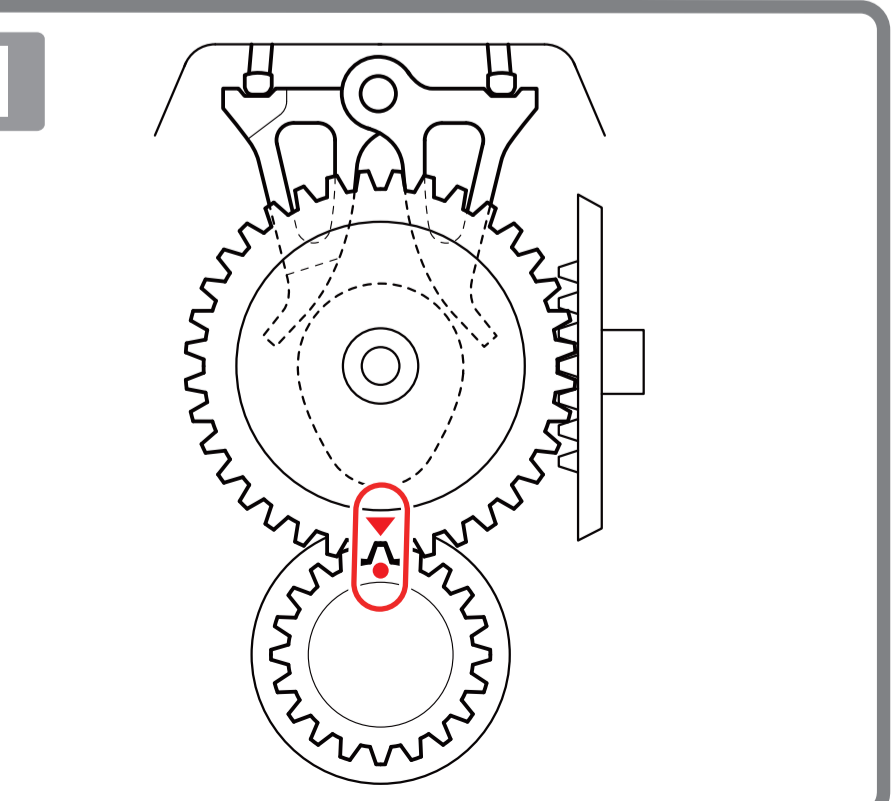

### Valve Clearance Adjustment

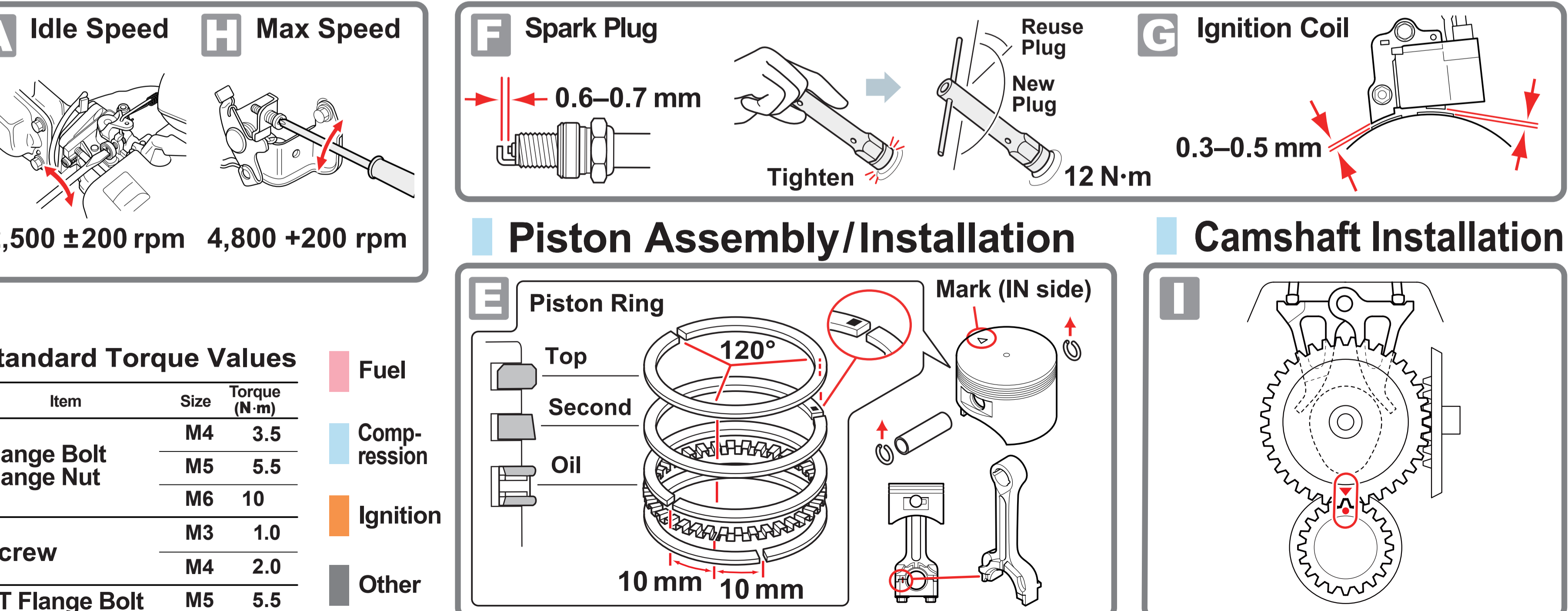

### Governor System Assembly

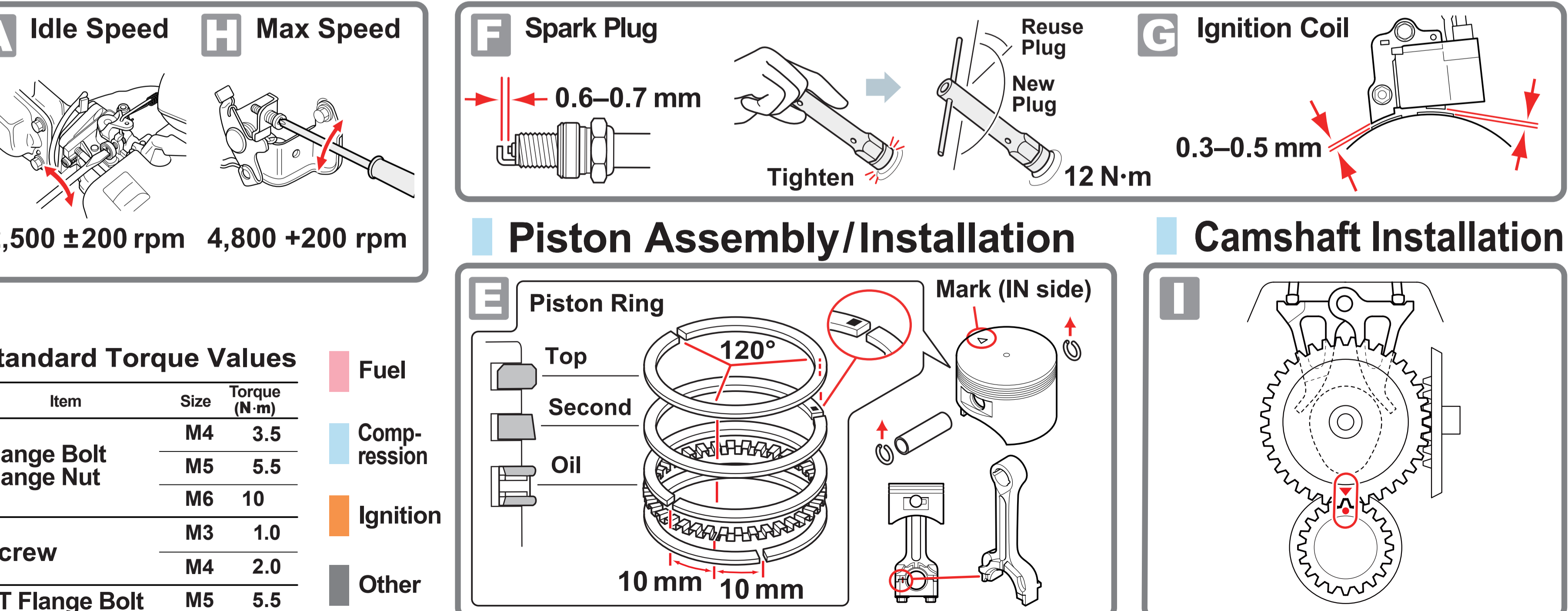

### Flywheel Removal/Installation

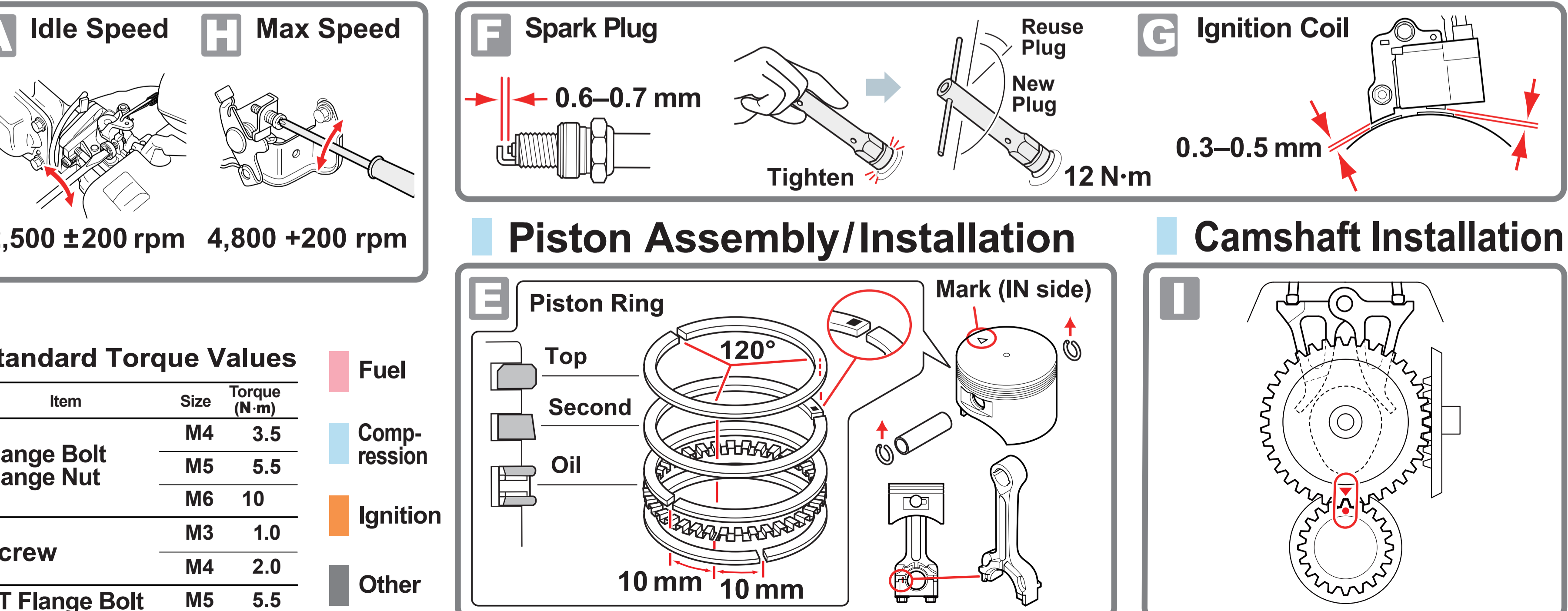

### Liquid Sealant

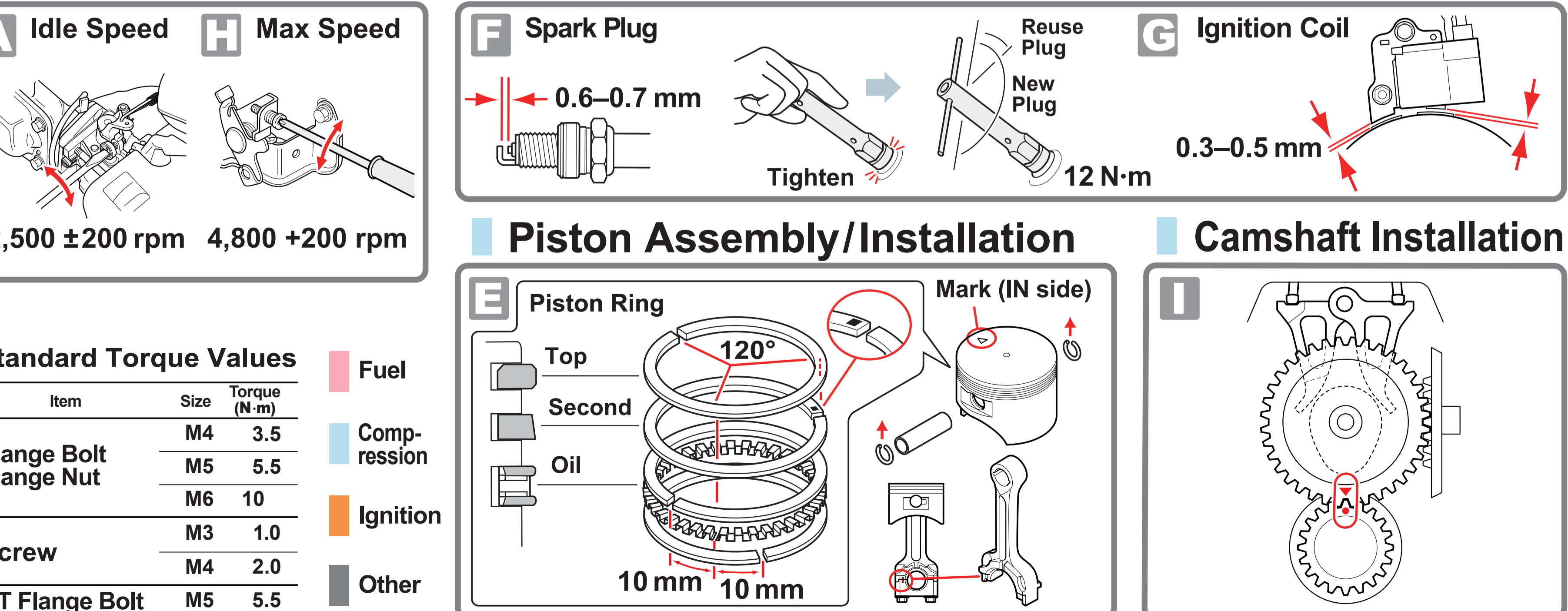

### Tightening Order

