

A FEW WORDS ABOUT SAFETY

SERVICE INFORMATION

The service and repair information contained in this manual is intended for use by qualified, professional technicians. Attempting service or repairs without the proper training, tools, and equipment could cause injury to you or others. It could also damage the engine or create an unsafe condition.

This manual describes the proper methods and procedures for performing service, maintenance, and repairs. Some procedures require the use of special tools. Any person who intends to use a replacement part, service procedure, or a tool that is not recommended by Honda, must determine the risks to their personal safety and the safe operation of the engine.

If you need to replace a part, use genuine Honda parts with the correct part number, or an equivalent part. We strongly recommend that you do not use replacement parts of inferior quality.

For Your Customer's Safety

Proper service and maintenance are essential to the customer's safety and the reliability of the engine. Any error or oversight while servicing an engine can result in faulty operation, damage to the engine, or injury to others.

For Your Safety

Because this manual is intended for the professional service technician, we do not provide warnings about many basic shop safety practices (eg, Hot parts – wear gloves). If you have not received shop safety training or do not feel confident about your knowledge of safe servicing practices, we recommend that you do not attempt to perform the procedures described in this manual.

Some of the most important general service safety precautions are given below. However, we cannot warn you of every conceivable hazard that can arise in performing service and repair procedures. Only you can decide whether or not you should perform a given task.

Important Safety Precautions

- Make sure you have a clear understanding of all basic shop safety practices and that you are wearing appropriate clothing and using safety equipment. When performing any service task, be especially careful of the following:
 - Read all of the instructions before you begin, and make sure you have the tools, the replacement or repair parts, and the skills required to perform the tasks safely and completely.
 - Protect your eyes by using proper safety glasses, goggles, or face shields any time you hammer, drill, grind, or work around pressurized air or liquids, and springs or other stored-energy components. If there is any doubt, put on eye protection.
 - Use other protective wear when necessary, for example, gloves or safety shoes. Handling hot or sharp parts can cause severe burns or cuts. Before you grab something that looks like it can hurt you, stop and put on gloves.
- Make sure the engine is off before you begin any servicing procedures, unless the instructions tell you to do otherwise. This will help eliminate several potential hazards:
 - Carbon monoxide poisoning from engine exhaust. Be sure there is adequate ventilation whenever you run the engine.
 - Burns from hot parts. Let the engine and exhaust system cool before working in those areas.
 - Injury from moving parts. If the instruction tells you to run the engine, be sure your hands, fingers, and clothing are out of the way.
- Gasoline vapors are explosive. To reduce the possibility of a fire or explosion, be careful when working around gasoline.
 - Use only a nonflammable solvent, not gasoline, to clean parts.
 - Never drain or store gasoline in an open container.
 - Keep all cigarettes, sparks, and flames away from all fuel-related parts.

WARNING

Improper service or repairs can create an unsafe condition that can cause your customer or others to be seriously hurt or killed.

Follow the procedures and precautions in this manual and other service materials carefully.

WARNING

Failure to properly follow instructions and precautions can cause you to be seriously hurt or killed.

Follow the procedures and precautions in this manual carefully.

NAVIGATION QUICKTIPS – ELECTRONIC SHOP MANUAL

- ⏪ to the 1st page of the manual
- ⏩ Back one page
- ⏪ Forward one page
- ⏩ to the last page of the manual

File Name: Shows the Shop Manual Model/Serial Number that you are looking at: Eg3500 (410001–4110497)

Page Magnification

Print

'+' click to open more bookmarks
'-' click to condense the bookmarks



Clicking on a bookmark will take you to that page

Retrace your steps:
⏪ backward, or ⏩ Forward within the CD.

GREEN BOX LINKS
Click here to go to this page in the manual

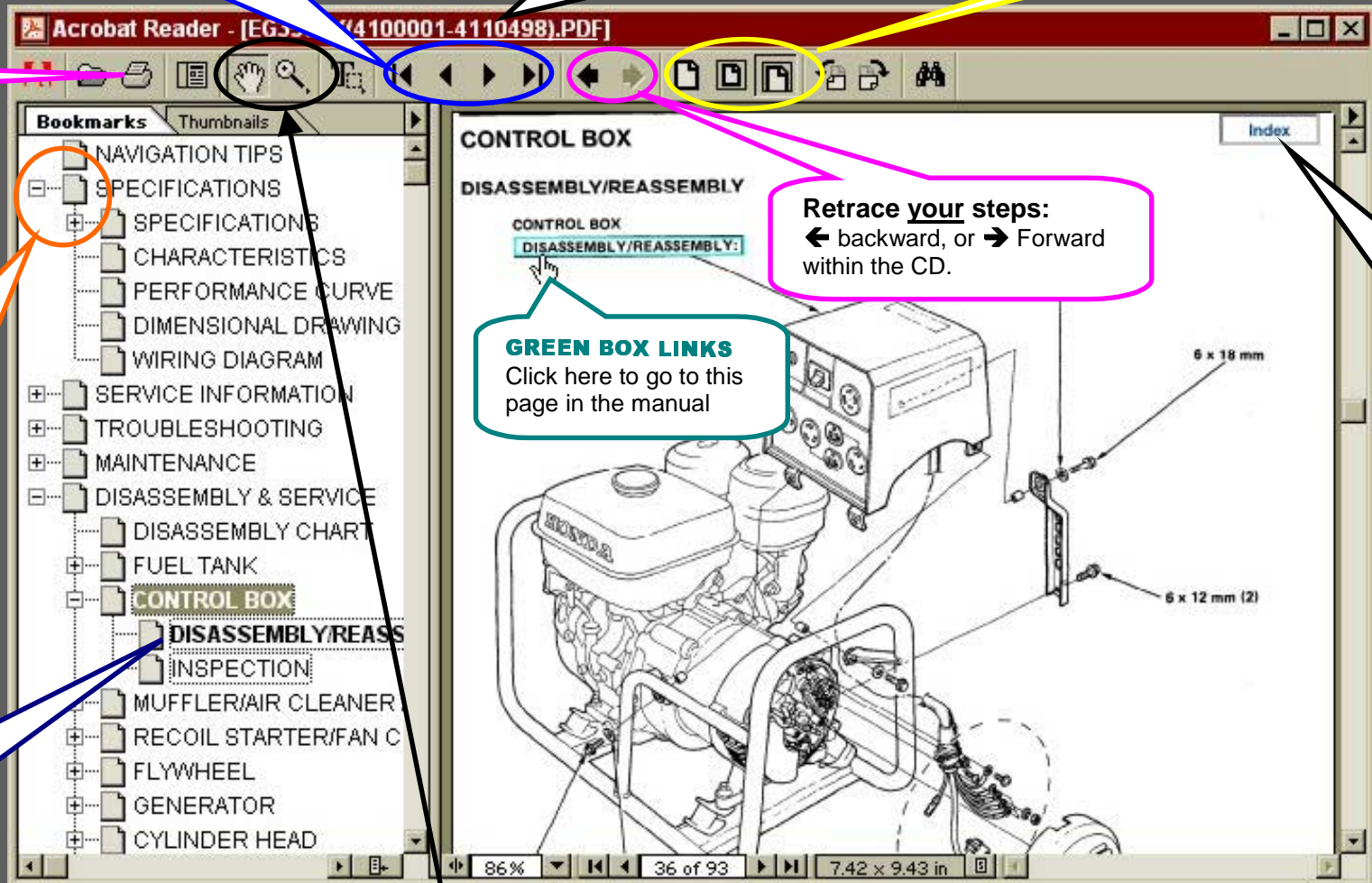
Click INDEX to go BACK to the serial number page



-  Use hand to grab the page and move it up/down; left/right, depending on page view magnification.
-  To magnify page image: Click on button, place the magnifying glass on the area to zoom in and click. Hold the CTRL key and click to zoom out.

ENGINE SPECIFICATIONS

Engine model	GC190
Engine type	4-stroke, overhead-cam, single-cylinder
Displacement	187 cc (11.4 cu)
Bore and stroke	69 x 50 mm (2.71 x 1.97 in)
Compression ratio	8.5:1
Fuel consumption	313 g/kWh (230 g/Hph, 0.51 lb/Hph)
Maximum horsepower	4.4 kW (6.0 hp) @ 3,600 rpm
Maximum torque	12.1 N•m (8.9 ft-lb) @ 2,500 rpm
Maximum governed speed	3,850 ± 150 rpm
Ignition system	Transistorized magneto ignition
Ignition timing	20° B.T.D.C
Spark plug	BPR6ES (NGK)
Fuel supply system	Diaphragm type fuel pump
Lubrication system	Splash type
Oil capacity	0.58 ℓ (0.61 US qt, 0.55 Imp qt)
Cooling system	Forced air
Recommended operating ambient temperature	-15°C - 40°C (5°F - 104°F)
Starting system	Recoil starter
Stopping system	Ignition primary circuit ground
Carburetor	Horizontal-type, butterfly valve
Air cleaner	Dry (paper) type
Governor	Centrifugal mechanical governor
Fuel Used	Unleaded gasoline with a pump octane number 86 or higher
Fuel tank capacity	2.0 ℓ (0.53 US gal, 0.44 Imp gal)
PTO shaft rotation	Counterclockwise (from PTO shaft side)

DIMENSIONS AND WEIGHTS

Item	PTO type	Q	V	P
Overall length		345 mm (13.582 in)	355 mm (13.976 in)	345 mm (13.582 in)
Overall width		369 mm (14.5 in)		
Overall height		331 mm (13.03 in)		
Dry weight		13.2 kg (29.1 lb)		
Operating weight		15.2 kg (33.51 lb)		

PERFORMANCE CURVES

Power curves are according to SAE standard No. J-1995. For practical operations, the bhp load and engine speed should not exceed the limit defined by the "Recommended Maximum Operating bhp" curve. Continuous operation should not exceed 80% of the "Maximum bhp".

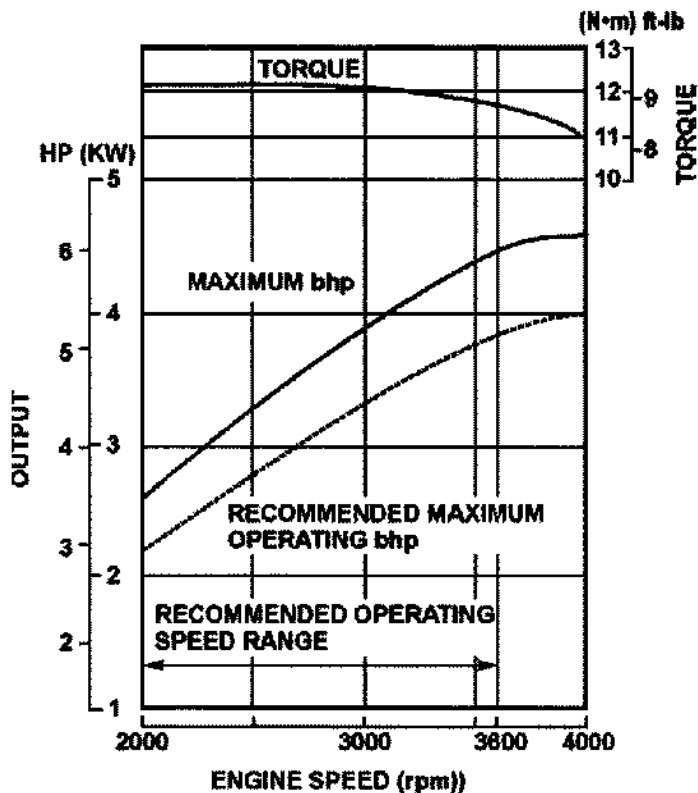

DIMENSIONAL DRAWINGS

unit: mm (in)

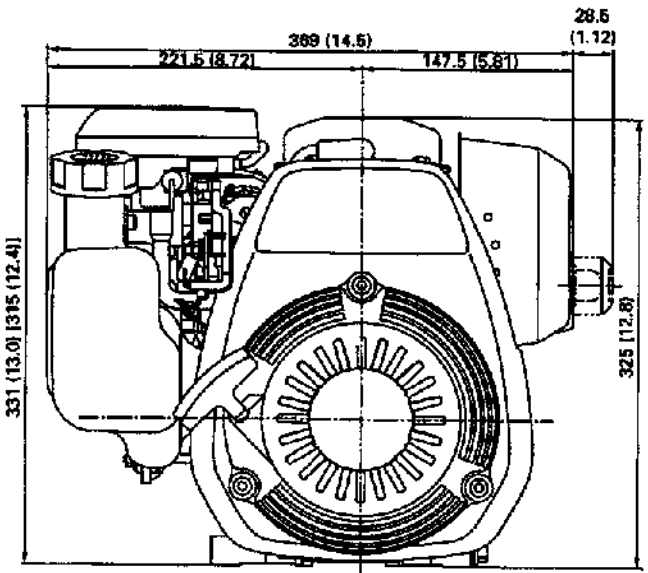
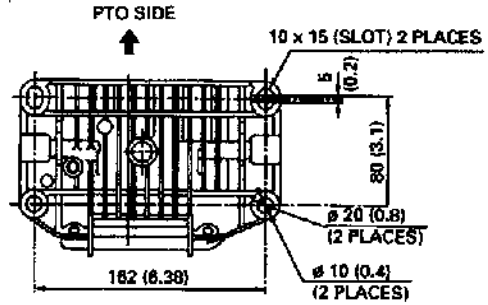
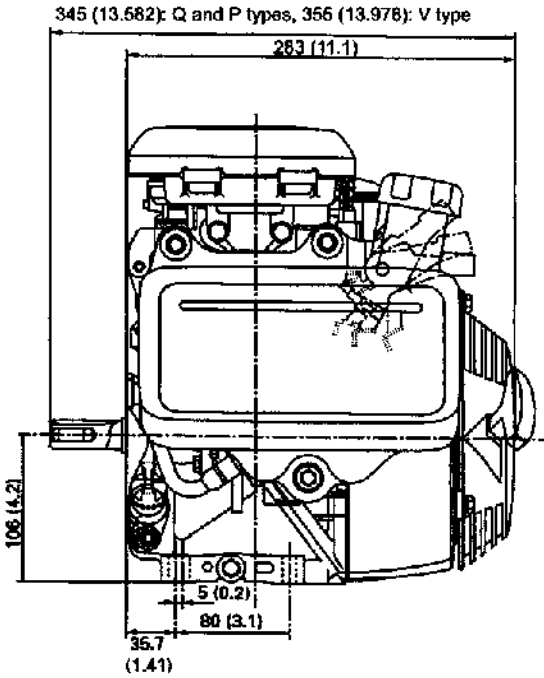
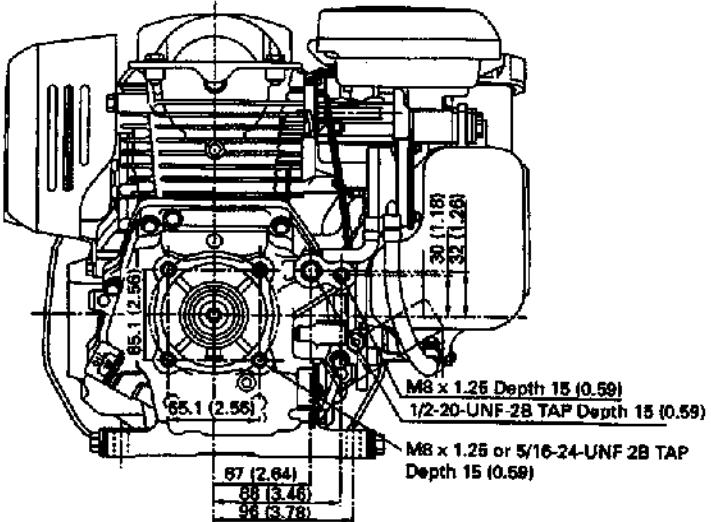

PTO DIMENSIONAL DRAWINGS

Unit: mm (in)

• Q type

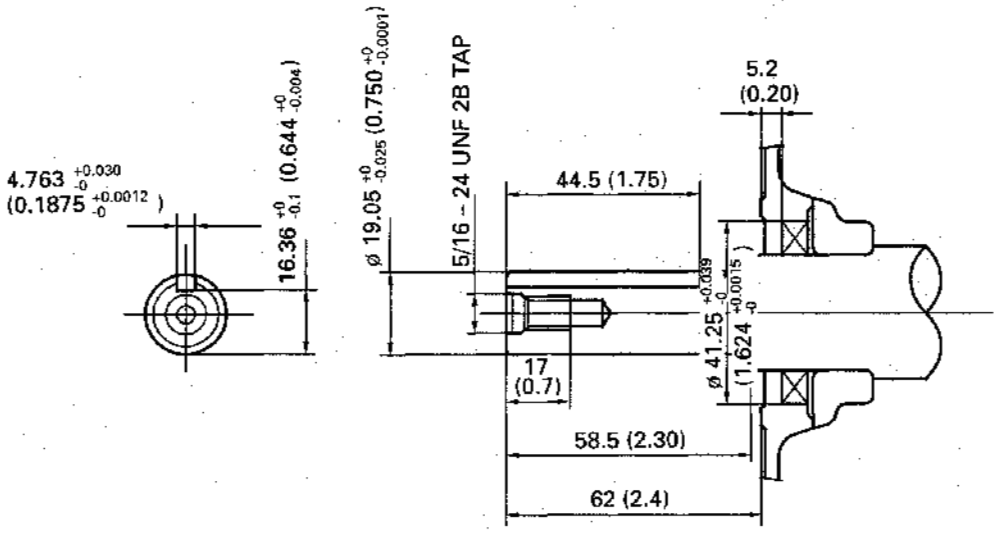

• V type

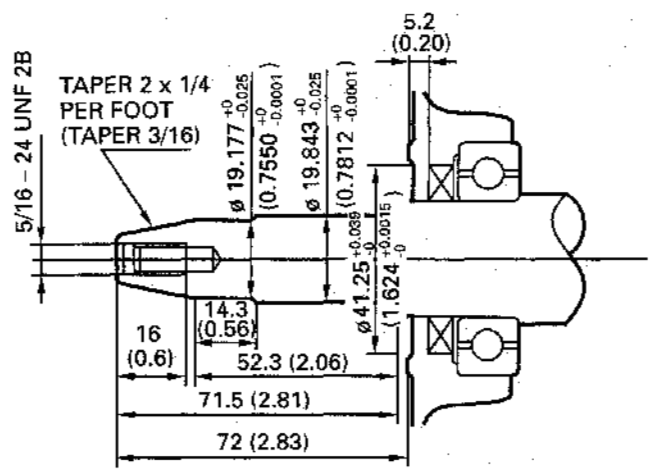

• P type

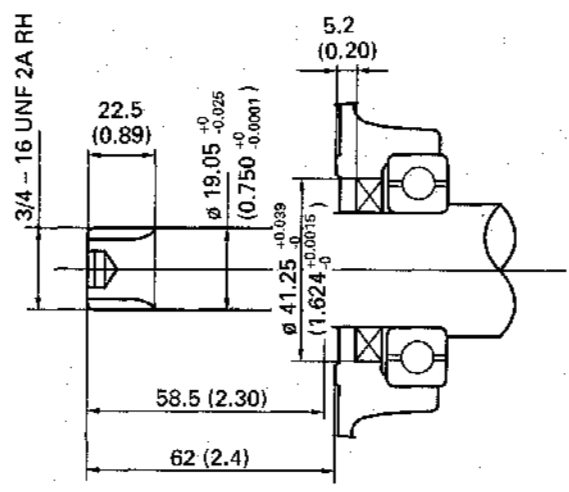

WIRING DIAGRAMS

• With oil level switch

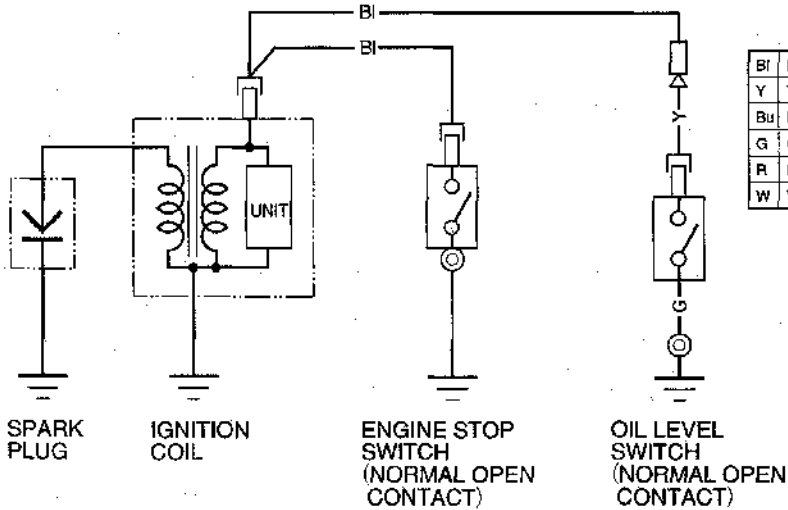

Bl	Black	Br	Brown
Y	Yellow	O	Orange
Bu	Blue	Lb	Light blue
G	Green	Lg	Light green
R	Red	P	Pink
W	White	Gr	Gray

ENGINE	SWITCH CONTACT
RUN	OPEN
STOP	CLOSE

OIL LEVEL	SWITCH CONTACT	ENGINE
NORMAL	OPEN	RUN
LOW LEVEL	CLOSE	STOP

• Without oil level switch

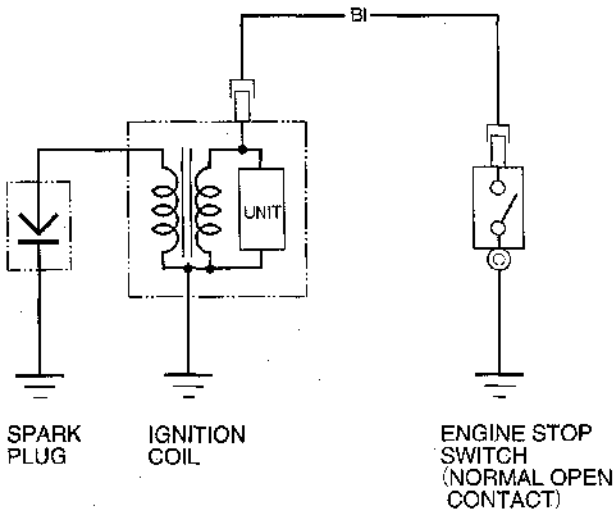

Bl	Black	Br	Brown
Y	Yellow	O	Orange
Bu	Blue	Lb	Light blue
G	Green	Lg	Light green
R	Red	P	Pink
W	White	Gr	Gray

ENGINE	SWITCH CONTACT
RUN	OPEN
STOP	CLOSE

THE IMPORTANCE OF PROPER SERVICING

Proper servicing is essential to the safety of the operator and the reliability of the engine. Any error or oversight made by the technician while servicing can easily result in faulty operation, damage to the engine or injury to the operator.

WARNING

Improper servicing can cause an unsafe condition that can lead to serious injury or death. Follow the procedures and precautions in this shop manual carefully.

Some of the most important precautions are given below. However, we cannot warn you of every conceivable hazard that can arise in performing maintenance or repairs. Only you can decide whether or not you should perform a given task.

WARNING

Failure to follow maintenance instructions and precautions can cause you to be seriously hurt or killed. Follow the procedures and precautions in this shop manual carefully.

IMPORTANT SAFETY PRECAUTIONS

Be sure you have a clear understanding of all basic shop safety practices and that you are wearing appropriate clothing and safety equipment. When performing maintenance or repairs, be especially careful of the following:

- **Read the instructions before you begin, and be sure you have the tools and skills required to perform the tasks safely.**

Be sure the engine is off before you begin any maintenance or repairs. This will reduce the possibility of several hazards:

- **Carbon monoxide poisoning from engine exhaust.**

Be sure there is adequate ventilation whenever you run the engine.

- **Burns from hot parts.**

Let the engine cool before you touch it.

- **Injury from moving parts.**

Do not run the engine unless the instruction tells you to do so. Even then, keep your hands, fingers, and clothing away.

To reduce the possibility of a fire or explosion, be careful when working around gasoline. Use only a nonflammable solvent, not gasoline, to clean parts. Keep all cigarettes, sparks, and flames away from all fuel-related parts.

SERIAL NUMBER LOCATION

The engine serial number is stamped on the cylinder barrel. Refer to this when ordering parts or making technical inquiries.

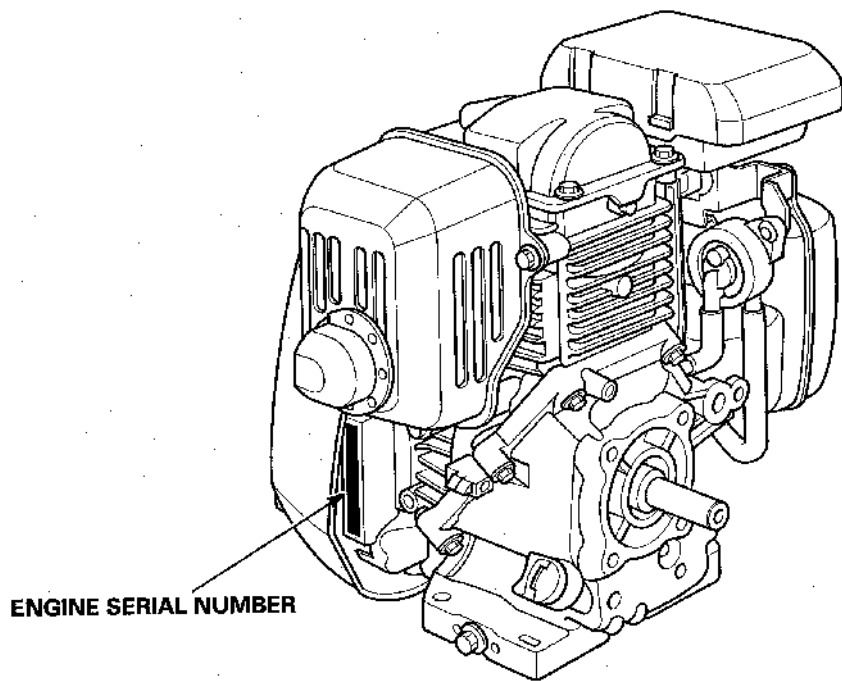

SERVICE RULES

1. Use genuine Honda or Honda-recommended parts and lubricants or their equivalents. Parts that do not meet Honda's design specifications may damage the engine.
2. Use the special tools designed for the product.
3. Install new gaskets, O-rings, etc. when reassembling.
4. When torquing bolts or nuts, begin with larger-diameter or inner bolts first and tighten to the specified torque diagonally, unless a particular sequence is specified.
5. Clean parts in cleaning solvent upon disassembly. Lubricate any sliding surfaces before reassembly.
6. After reassembly, check all parts for proper installation and operation.
7. Many screws used in this machine are self-tapping. Be aware that cross-threading or overtightening these screws will strip the threads and ruin the hole.
8. Use only metric tools when servicing this engine. Metric bolts, nuts and screws are not interchangeable with nonmetric fasteners. The use of incorrect tools and fasteners will damage the engine.
9. Follow the instructions represented by these symbols when they are used:

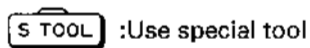
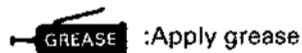

○ x ○ (○): Indicates the diameter, length, and number of the flange bolt used.

MAINTENANCE STANDARDS

Part	Item	Standard	Service limit
Engine	Maximum speed	3,850 ± 150 rpm	—
	Idle speed	1,400 ± 150 rpm	—
	Cylinder compression	0.49 MPa (5.0 kgf/cm ² , 71 psi) at 600 rpm	—
Carburetor	Main jet	#68	—
	Float height	9.2 mm (0.36 in)	—
	Pilot screw opening	GC160: 1-3/4 turns out	—

MAINTENANCE STANDARDS

Part	Item	Standard	Service limit
Spark plug	Gap	0.7 – 0.8 mm (0.028 – 0.031 in)	—
Ignition coil	Resistance	Primary coil	1.0 – 1.2 Ω
		Secondary coil	10.6 – 12.8 k Ω
	Air gap	(at flywheel)	0.2 – 0.6 mm (0.008 – 0.024 in)

MAINTENANCE STANDARDS

Part	Item		Standard	Service limit
Valves	Valve clearance (cold)	IN	0.15 ± 0.04 mm	—
		EX	0.20 ± 0.04 mm	—
	Stem O. D.	IN	5.48 mm (0.216 in)	5.318 mm (0.2094 in)
		EX	5.44 mm (0.214 in)	5.275 mm (0.2077 in)
	Guide I. D.	IN/EX	5.50 mm (0.217 in)	5.572 mm (0.2194 in)
	Seat width	IN/EX	0.7 mm (0.028 in)	1.8 mm (0.07 in)
	Spring free length	IN/EX	34.0 mm (1.34 in)	32.5 mm (1.28 in)
	Valve head diameter	IN	25 mm (0.98 in)	
EX		24 mm (0.94 in)		

MAINTENANCE STANDARDS

Part	Item	Standard	Service limit
Connecting rod	Small end I. D.	13.005 mm (0.5120 in)	13.07 mm (0.515 in)
	Big end I. D.	30.02 mm (1.1819 in)	30.066 mm (1.1837 in)
	Big end oil clearance	0.040 - 0.063 mm (0.0016 - 0.0025 in)	0.12 mm (0.005 in)
	Big end axial clearance	0.1 - 0.4 mm (0.004 - 0.016 in)	0.8 mm (0.031 in)
Crankshaft	Main journal O. D. PTO side	27.993 mm (1.1021 in)	27.933 mm (1.0997 in)
	Flywheel side	25.393 mm (0.9997 in)	25.333 mm (0.9974 in)
	Crank pin O. D.	29.980 mm (1.1803 in)	29.92 mm (1.1780 in)
	Axial clearance	0.15-0.75 mm (0.006-0.030 in)	1.0 mm (0.04 in)
Crankcase cover	Main journal I. D.	28.020 mm (1.1031 in)	28.066 mm (1.1050 in)
Cam pulley	Cam height	37.394 mm (1.4722 in)	37.369 mm (1.4712 in)
	Cam pulley I. D. (Bearing)	10.027 mm (0.3948 in)	10.075 mm (0.3967 in)
	Cam pulley shaft O. D.	9.987 mm (0.3932 in)	9.920 mm (0.3906 in)
Rocker arm	Rocker arm I. D.	6.000 mm (0.2362 in)	6.043 mm (0.2379 in)
	Rocker arm shaft O. D.	5.990 mm (0.2368 in)	5.953 mm (0.2344 in)
	Rocker arm shaft bearing I. D.	6.000 mm (0.2362 in)	6.043 mm (0.2379 in)
	Rocker arm shaft bearing-to-rocker arm shaft clearance	0.010-0.068 mm (0.0004-0.0023 in)	0.07 mm (0.003 in)

MAINTENANCE STANDARDS

Part	Item	Standard	Service limit	
Cylinder	Sleeve I. D.	69.000 mm (2.7165 in)	69.165 mm (2.2730 in)	
Piston	Skirt O. D.	68.985 mm (2.7159 in)	68.885 mm (2.7120 in)	
	Piston-to-cylinder clearance	0.031 - 0.070 mm (0.0012 - 0.0028 in)	0.12 mm (0.005 in)	
	Piston pin bore I. D.	13.002 mm (0.5119 in)	13.048 mm (0.5137 in)	
	Pin O. D.	13.000 mm (0.5118 in)	12.954 mm (0.5100 in)	
Piston ring	Ring width	Top/second	1.5 mm (0.06 in)	1.37 mm (0.054 in)
		Oil	2.5 mm (0.10 in)	2.37 mm (0.093 in)
	Ring side clearance	Top	0.035 - 0.065 mm (0.0013 - 0.0026 in)	0.15 mm (0.006 in)
		Second	0.015 - 0.049 mm (0.0006 - 0.0019 in)	0.15 mm (0.006 in)
	Ring end gap	Top	0.20 - 0.35 mm (0.008 - 0.014 in)	1.0 mm (0.04 in)
		Second	0.30 - 0.45 mm (0.012 - 0.018 in)	1.0 mm (0.04 in)
Oil		0.15 - 0.35 mm (0.006 - 0.014 in)	1.0 mm (0.04 in)	
Cylinder barrel	Main journal I. D.	25.420 mm (1.0008 in)	25.466 mm (1.0026 in)	
	Crankshaft axial clearance	0.15 - 0.75 mm (0.006 - 0.030 in)	1.0 mm (0.04 in)	

TORQUE VALUES

Item	Thread Dia. (mm)	Torque		
		N·m	kgf·m	lbf·ft
Crankcase cover	M6 x 1.0 (CT)	12	1.2	9
Connecting rod bolt	M7 x 1.0	12	1.2	9
Valve adjusting lock nut	M5 x 0.5	8	0.8	5.8
Cylinder head cover bolt	M6 x 1.0	12	1.2	9
Oil drain plug bolt	M12 x 1.5	24	2.4	17
Flywheel nut	M14 x 1.5	75	7.6	55
Governor arm nut	M6 x 1.0	10	1.0	7
Breather cover bolt	M6 x 1.0	12	1.2	9
Air cleaner case bolt	M6 x 1.0 (CT)	10	1.0	7
Muffler bolt	M6 x 1.0 (CT)	12	1.2	9
Recoil starter nut	M6 x 1.0	8.5	0.85	6.1
Fan cover stud bolt	M6 x 1.0	12	1.2	9
Fuel tank stud bolt	M6 x 1.0	12	1.2	9
bolt, nut	M6 x 1.0	10	1.0	7
Fuel pump screw	M5 x 0.8	3	0.3	2.2
Oil level switch bolt (With oil level switch only)	M6 x 1.0	12	1.2	9
Oil filler extension bolt	M6 x 1.0 (CT)	12	1.2	9
Spark plug	M14 x 1.25	20	2.0	14

NOTE:

- Use standard torque values of fasteners that are not listed in this table.
- (CT) indicates a self-tapping bolt.

• STANDARD TORQUE VALUE

Item	Thread Dia. (mm)	Torque		
		N·m	kgf·m	lbf·ft
Screw	5 mm	4	0.4	2.9
	6 mm	9	0.9	6.5
Bolt and nut	5 mm	5	0.5	3.6
	6 mm	10	1.0	7
	8 mm	21	2.1	15
	10 mm	34	3.5	25
	12 mm	54	5.5	40
Flange bolt and nut	6 mm	12	1.2	9
	8 mm	26	2.7	20
	10 mm	39	4.0	29
SH bolt	6 mm	9	0.9	6.5

SPECIAL TOOLS

Tool name	Tool number	Application
1. Float level gauge	07701-0010000	Carburetor float level inspection
2. Valve adjusting wrench B	07708-0030400	Valve clearance adjustment
3. Attachment, 32 x 35 mm	07746-0010100	62/28 radial ball bearing removal (V and P types only)
4. Attachment, 52 x 55 mm	07746-0010400	62/28 radial ball bearing installation (V and P types only)
5. Pilot, 28 mm	07746-0041100	62/28 radial ball bearing removal/installation (V and P types only)
6. Driver	07749-0010000	Driver for tools 3, 4 and 5
7. Valve seat cutter, 45° \varnothing 27.2	07780-0010200	Valve seat reconditioning (IN/EX)
8. Cutter holder	07981-VA20100 or 07981-VA20101	Valve seat reconditioning
9. Cleaning brush	07998-VA20100	Combustion chamber cleaning

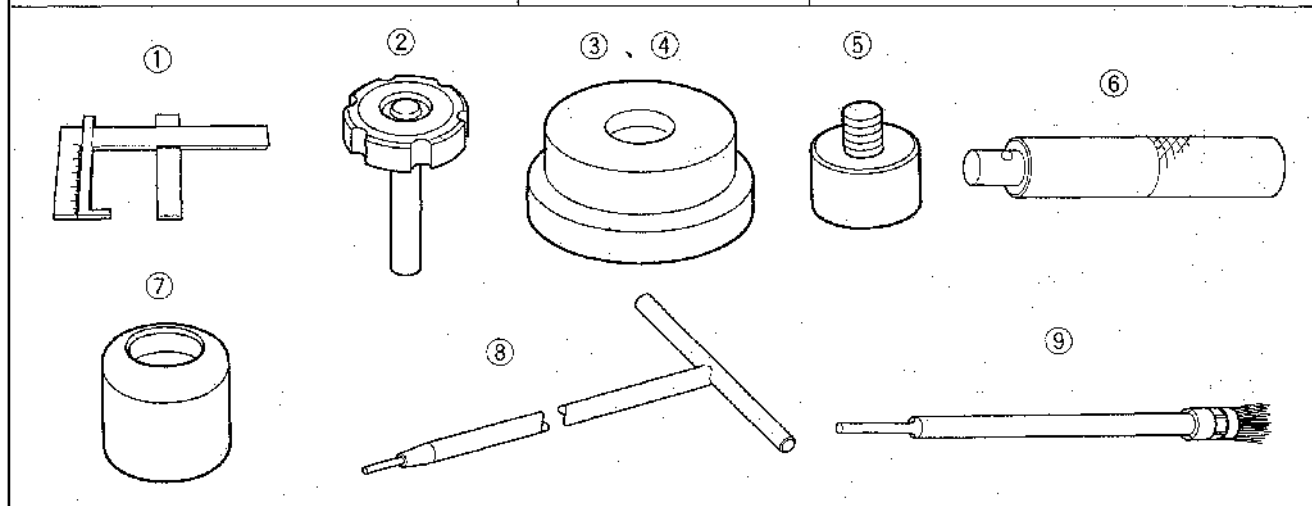

TROUBLESHOOTING

GENERAL SYMPTOMS AND POSSIBLE CAUSES

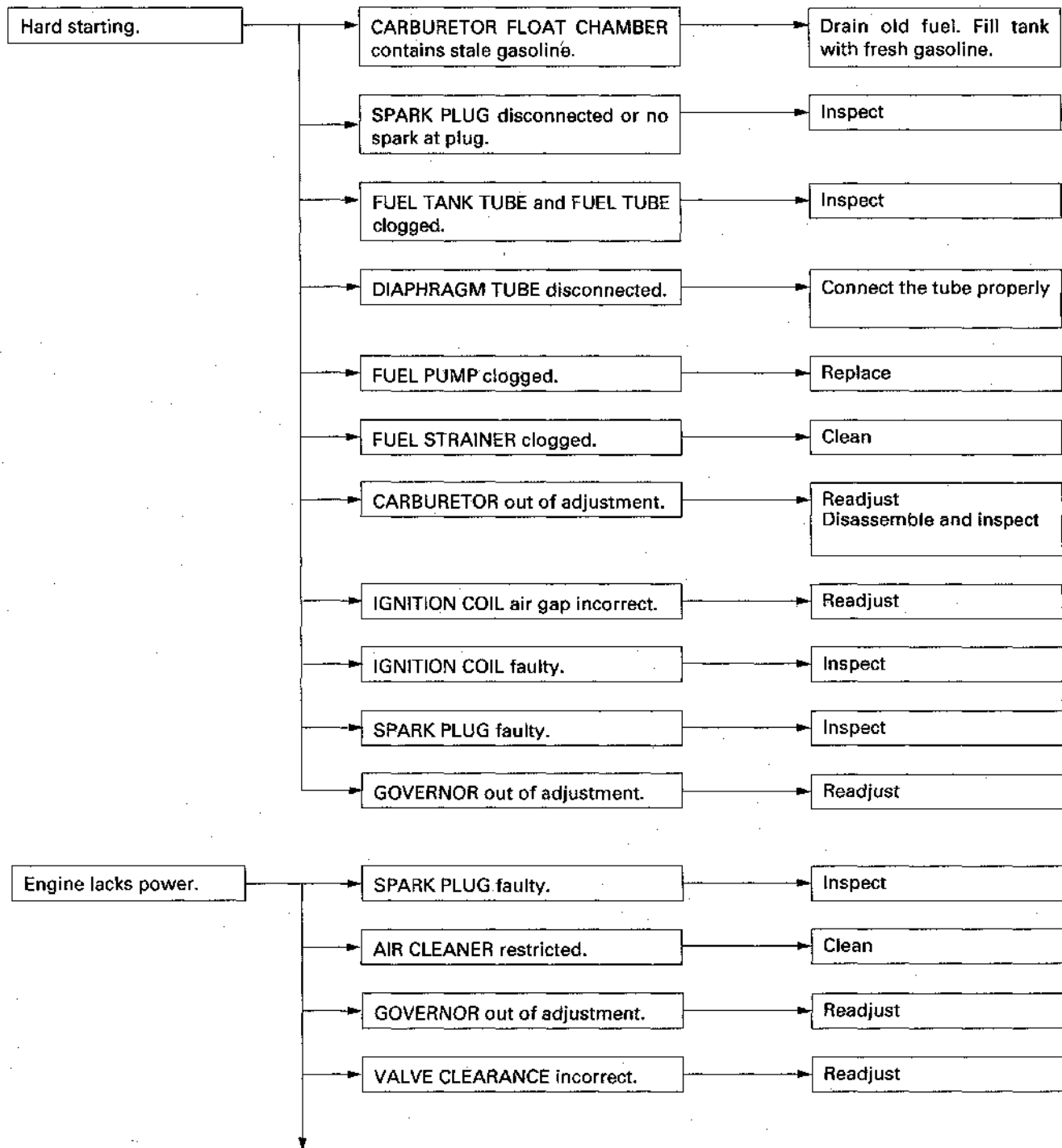

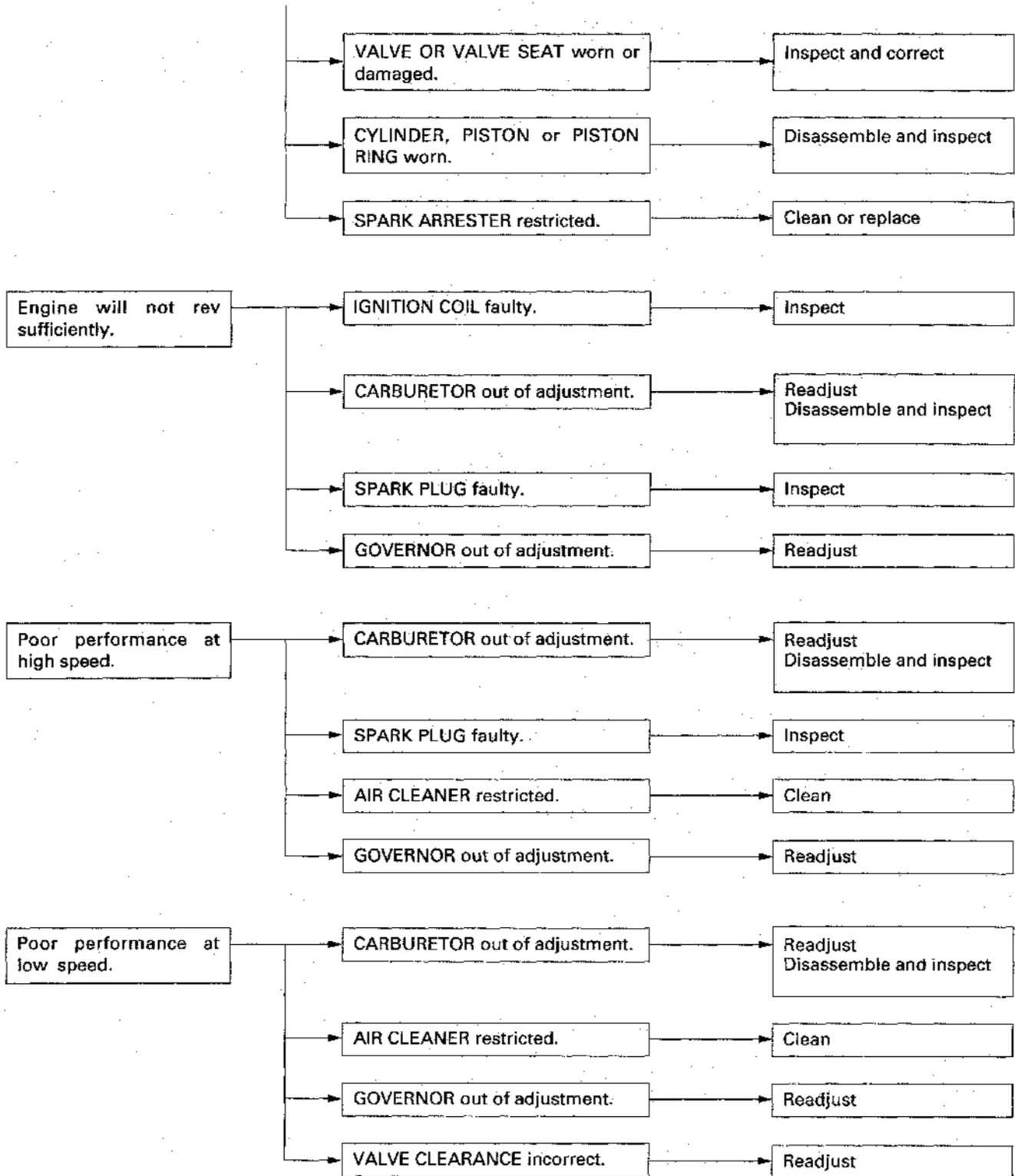

HARD STARTING

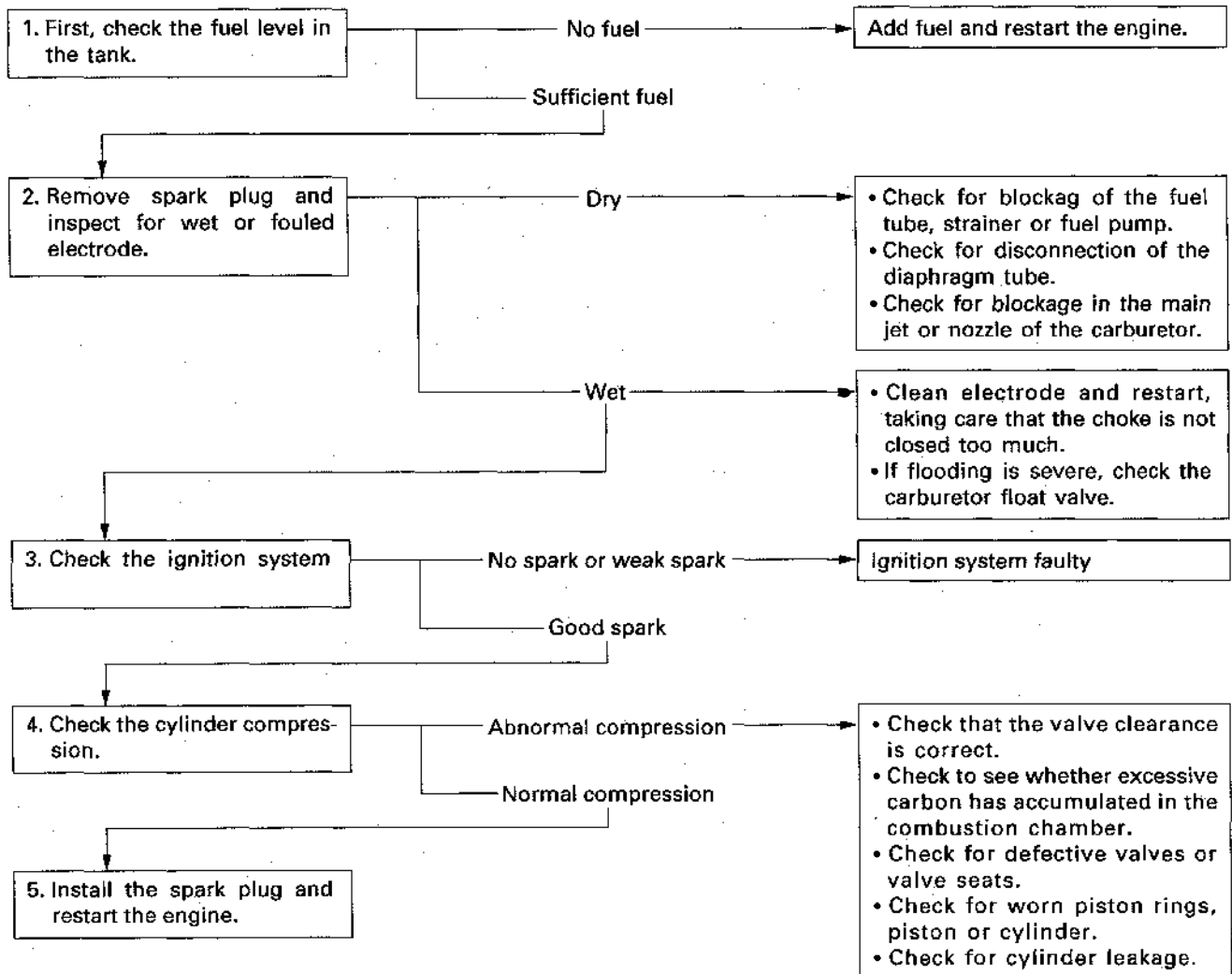

CYLINDER COMPRESSION CHECK

- 1) Remove the spark plug and install a compression gauge in the spark plug hole.
- 2) Pull the recoil starter several times with force and measure the cylinder compression.

Compression

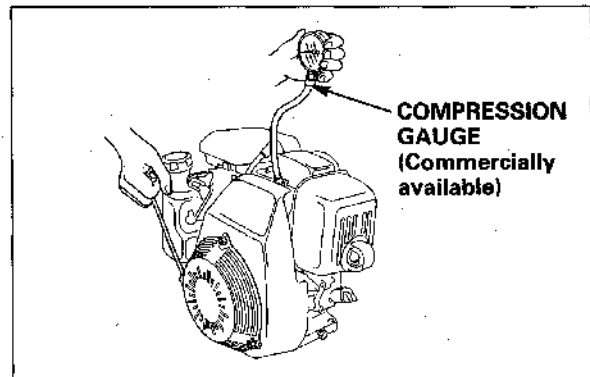

OIL ALERT SYSTEM (WITH OIL LEVEL SWITCH)

CAUTION:

Never start the engine when the oil has been drained.

Engine does not start with the ignition switch lever is moved to the ON position.

* Check oil level before proceeding. Add the recommended engine oil if necessary.

Check for sparks using new plug

Spark

Fault other than oil alert system
Perform troubleshooting

No spark

Check continuity between oil level switch yellow wire and ground.

Continuity

• OIL LEVEL SWITCH faulty.
• Replace oil level switch

No continuity

Disconnect the engine stop switch wire (Black) and recheck plug or spark.

Spark

• ENGINE STOP SWITCH faulty.
• Replace engine stop switch

No spark

• IGNITION COIL faulty.
• Replace ignition coil

Engine does not stop when the ignition switch lever is moved to the OFF position (Engine oil sufficient).

Disconnect the engine stop switch Black wire. Connect the Black wire of the ignition coil side to the ground and check spark at the spark plug.

No spark

• ENGINE STOP SWITCH faulty.
• Replace engine stop switch

Spark

• IGNITION COIL faulty.
• Replace ignition coil

Engine does not stop when the engine oil is insufficient.

Check continuity between oil level switch yellow wire and ground.

No continuity

• OIL LEVEL SWITCH faulty.
• Replace oil level switch

Continuity

Continuity

Disconnect the engine stop switch Black wire.
Connect the wire of the ignition coil side to ground and perform spark test

No,
spark

- ENGINE STOP SWITCH faulty.
- Replace engine stop switch

Spark

- IGNITION COIL faulty.
- Replace ignition coil

IGNITION SYSTEM

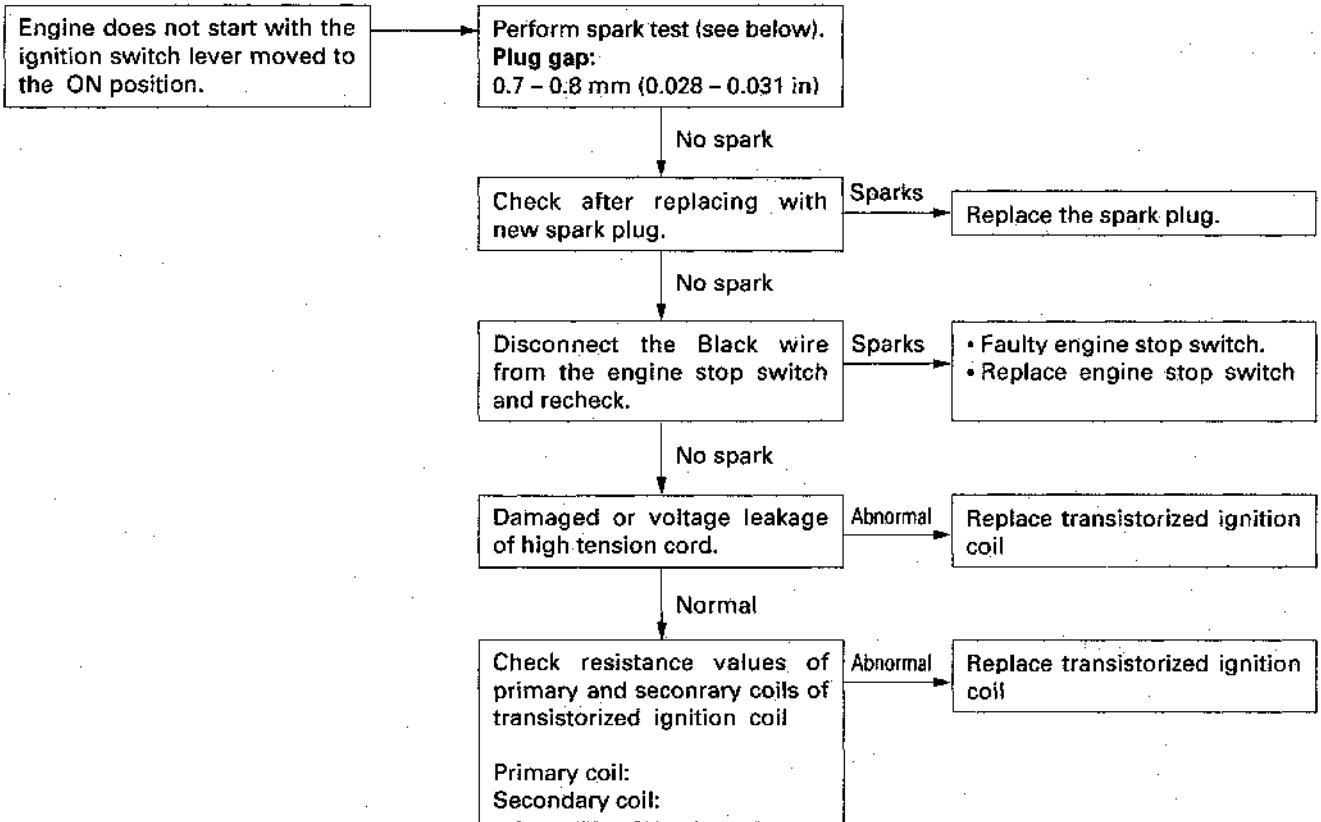

SPARK PLUG TEST

- 1) Remove the spark plug, attach it to the spark plug cap, and ground the side electrode against the cylinder head cover bolt.
- 2) Move the ignition switch lever to the ON position, pull the recoil starter and check to see if sparks jump across the electrodes.

WARNING

Gasoline is highly flammable and explosive.

If ignited, gasoline can burn you severely.

- Be sure there is no spilled fuel near the engine.
- Place the spark plug away from the spark plug hole.

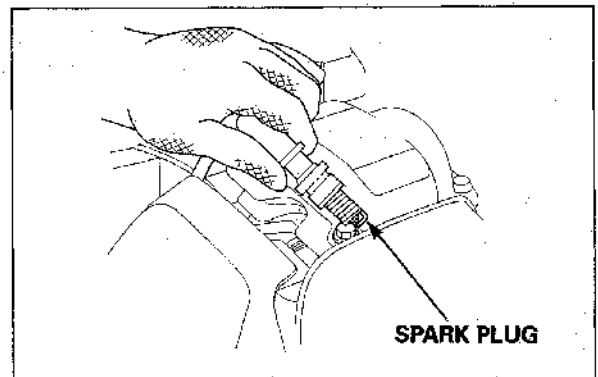

ENGINE STARTS BUT THEN STALLS

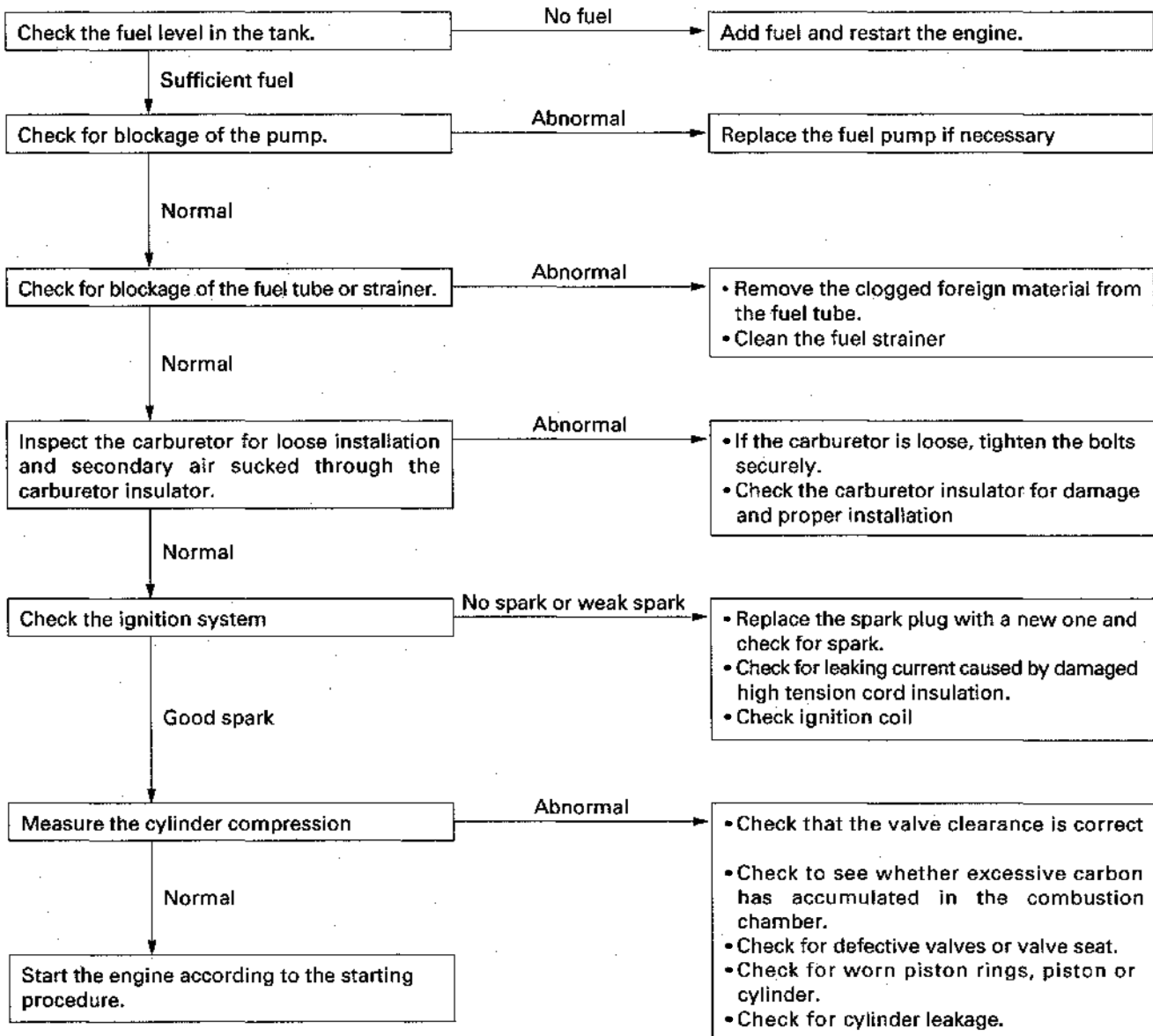

ENGINE LACKS POWER

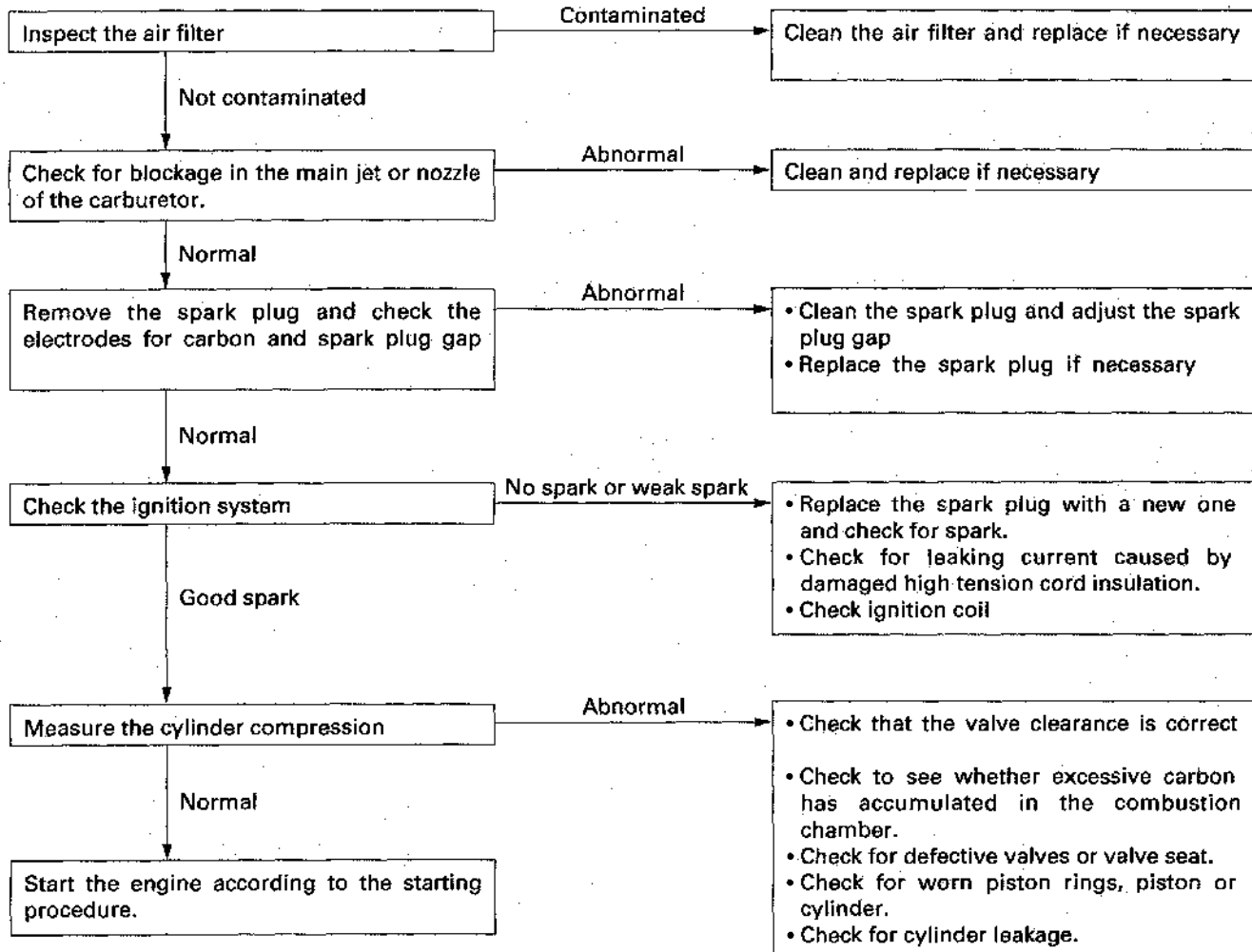

ENGINE SPEED DOES NOT INCREASE

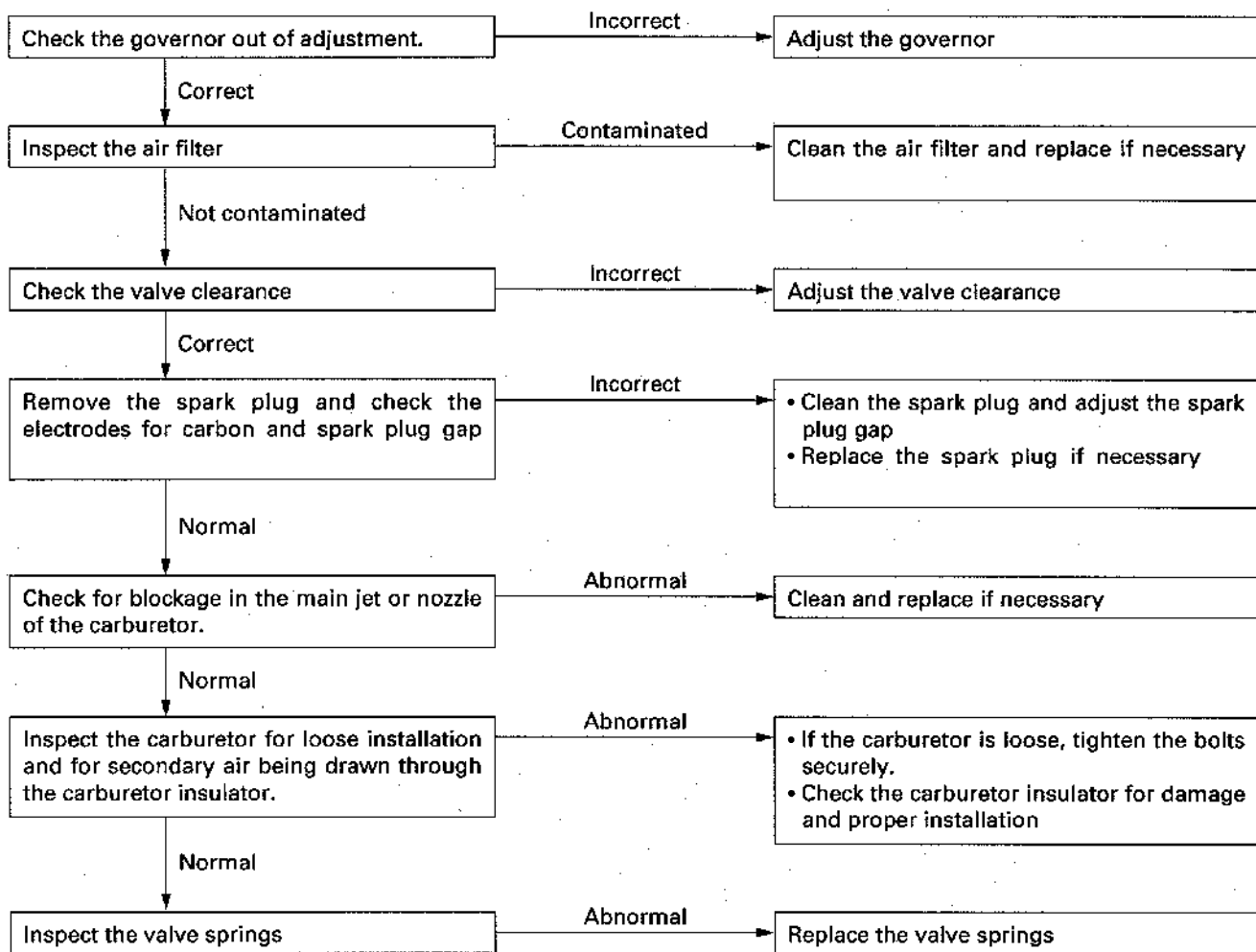

HARNES ROUTING

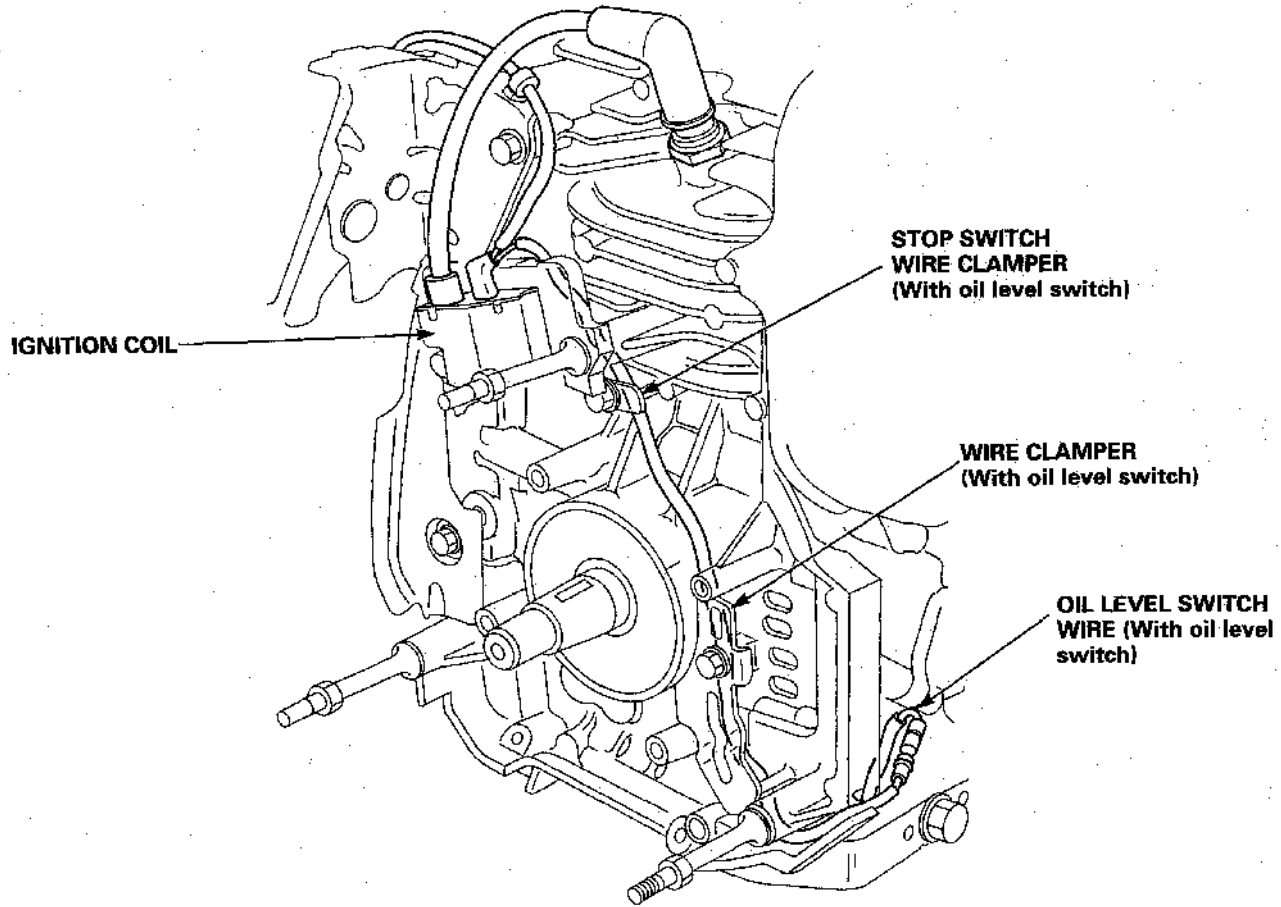
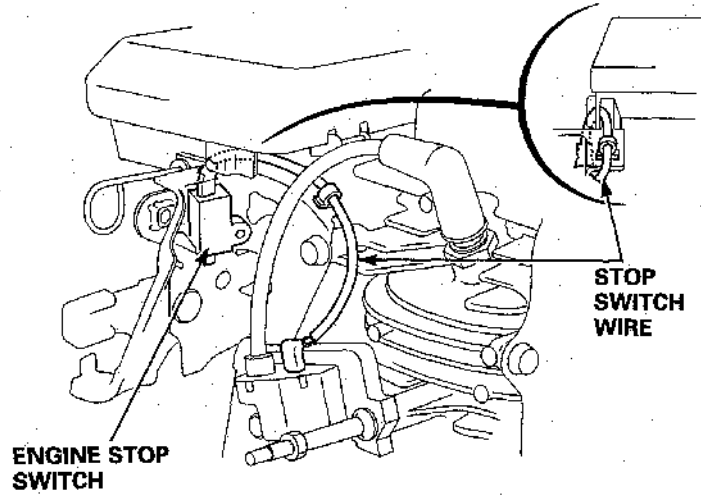
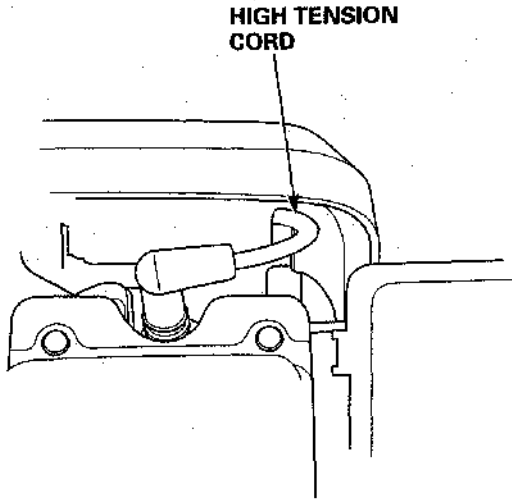

MAINTENANCE SCHEDULE

REGULAR SERVICE PERIOD			BEFORE USE	FIRST MONTH OR 5 HRS	EVERY SEASON OR 25 HRS	EVERY SEASON OR 50 HRS	EVERY 100 HRS	EVERY 150 HRS
ITEM	Perform at every indicated month or operating hour interval, whichever comes first (3).							
● Engine oil	Check		<input type="radio"/>					
	Change			<input type="radio"/>		<input type="radio"/> (1)		
● Air cleaner	Check		<input type="radio"/>					
	Clean				<input type="radio"/> (2)			
	Change							<input type="radio"/> (200HRS)
● Fuel tank and strainer	Clean					<input type="radio"/>		
● Spark plug	Check-Clean					<input type="radio"/>		
	Replace							<input type="radio"/> (200HRS)
Spark arrester (Optional part)	Clean					<input type="radio"/>		
● Idle speed	Check-Adjust							<input type="radio"/>
● Valve clearance	Check-Adjust							<input type="radio"/>
● Fuel line	Check (Replace if necessary)							Every 2 years

● Emission related items.

(1) Change engine oil every 25 hours when used under heavy load or in high ambient temperature.

(2) Service more frequently when used in dusty areas.

(3) For commercial use, log hours of operation to determine proper maintenance.

ENGINE OIL

Oil alert (with oil level switch only):

NOTE:

For convenience, perform this test in conjunction with the engine oil change.

- 1) With the engine running, disconnect the black wire from the stop switch wire, and ground the wire against the engine. The engine should stop.
- 2) With the engine stopped, the crankcase filled with oil, and the oil level switch wires disconnected, check continuity between the yellow oil level switch wire and ground. There should be no continuity.
- 3) With the engine stopped, the oil drained from the crankcase, and the oil level switch wires disconnected, check continuity between the yellow oil level switch wire and ground. There should be continuity.

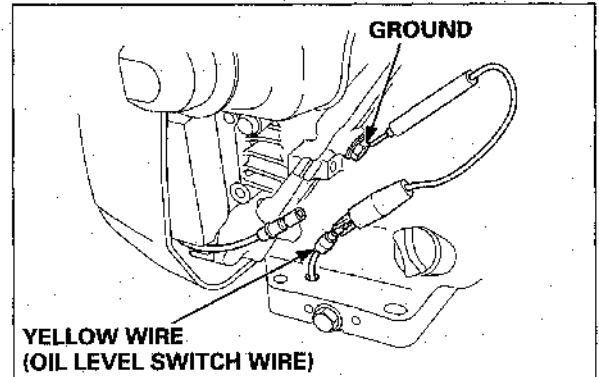
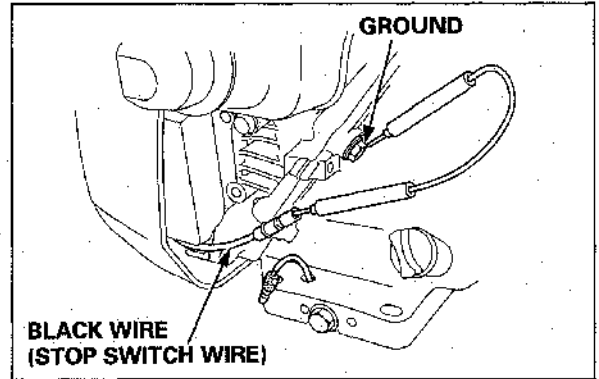

Oil level check:

Check the engine oil level with the engine stopped and engine on a level surface.

- 1) Remove the oil filler cap, and wipe the dipstick clean.

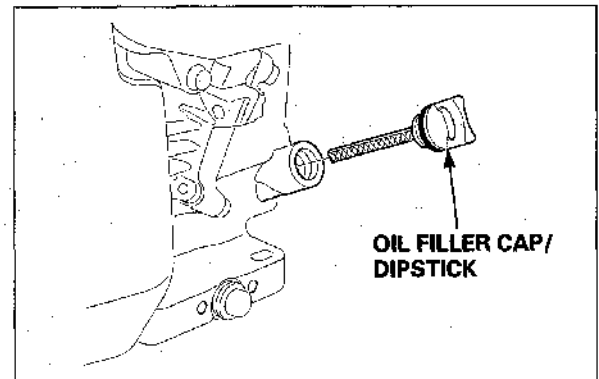

- 2) Insert the dipstick in the oil filler neck, but do not screw it in. Remove the dipstick and check the oil level.
- 3) If the oil level is low, fill to the top of the oil filler neck with the recommended oil. Do not overfill.
- 4) Tighten the oil filler cap securely.

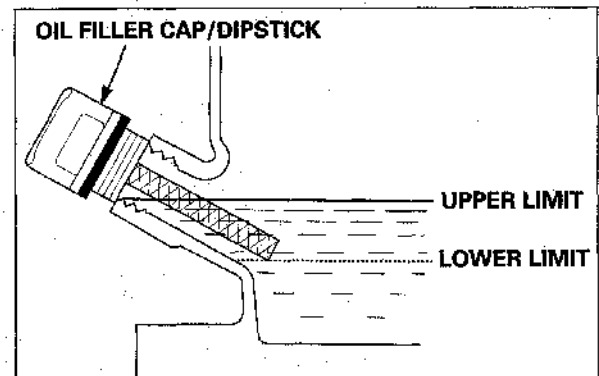

Oil change:

Drain the used oil while the engine is warm. Warm oil drains quickly and completely.

- 1) Place a suitable container under the oil drain plug bolt.
- 2) Remove the oil filter cap and drain plug bolt, and drain the oil into the suitable container.

Please dispose of used motor oil in a manner that is compatible with the environment. We suggest you take used oil in a sealed container to your local recycling center or service station for reclamation. Do not throw it in the trash, pour it on the ground, or down a drain.

CAUTION:

Used engine oil contains substances that have been identified as carcinogenic.

If repeatedly left in contact with the skin for prolonged periods, it may cause skin cancer.

Wash your hands thoroughly with soap and water as soon as possible after contact with used engine oil.

- 3) Reinstall the drain plug bolt, and tighten it securely.

TORQUE

- 4) With the engine on a level surface, refill with the recommended oil to the top of the oil filter neck.

Engine oil capacity

Recommended operating
ambient temperature

Oil is a major factor affecting performance and service life. Use 4-stroke automotive detergent oil.

SAE 10W-30 is recommended for general use. Other viscosities shown in the chart may be used when the average temperature in your area is within the recommended range. The SAE oil viscosity and service classification are in the API label on the oil container. Honda recommends that you use API SERVICE category SF or SG oil.

- 5) Reinstall the dipstick, and tighten the oil filter cap securely.

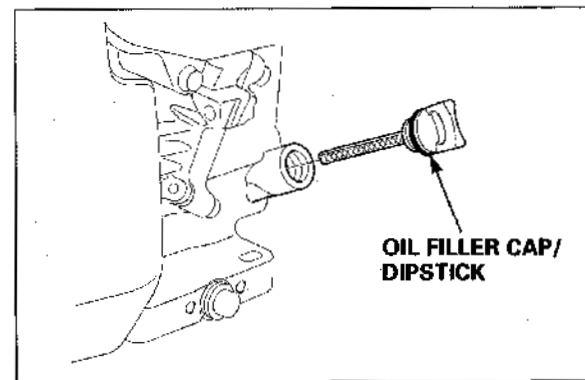
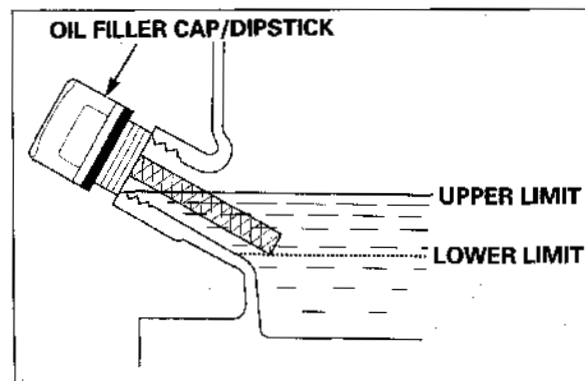
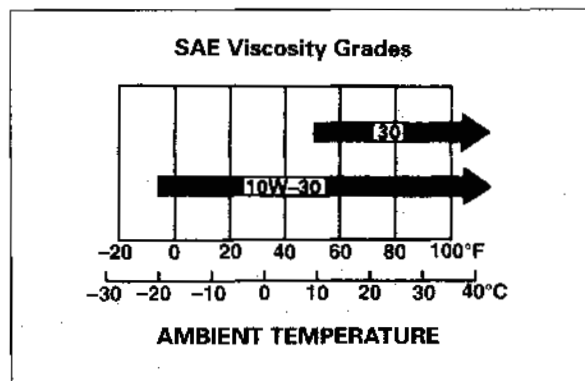
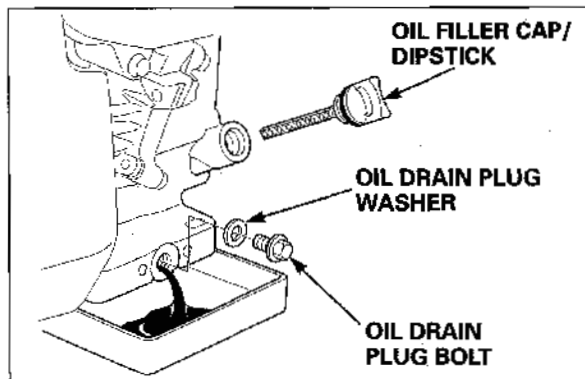

AIR CLEANER

Cleaning:

A dirty air filter will restrict air flow to the carburetor, reducing engine performance. If the filter is operated in dusty areas, clean the air filter more often than specified in the MAINTENANCE SCHEDULE.

CAUTION:

Operating the engine without an air filter or with a damaged air filter, will allow dirt to enter the engine, causing rapid engine wear. This type of damage is not covered by the Distributor's Limited Warranty.

- 1) Press the latch tabs on the fuel tank side of the air cleaner cover, and remove the cover.
- 2) Inspect the air filter, and replace if damaged.
- 3) Tap the filter several times on a hard surface to remove dirt, or blow compressed air [not exceeding 207 kPa (2.1 kgf/cm², 30 psi)] through the filter from the clean side that faces the engine.
Never try to brush off dirt; brushing will force dirt into the fibers.
- 4) Wipe dirt from the inside of the air cleaner cover and air cleaner case, using a moist rag. Be careful to prevent dirt from entering the air duct that leads to the carburetor.
- 5) Reinstall the filter and air cleaner cover.

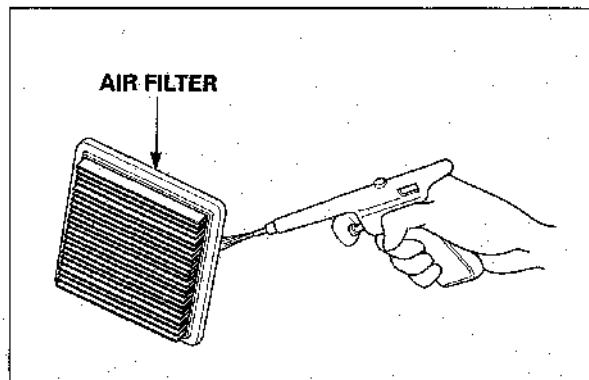
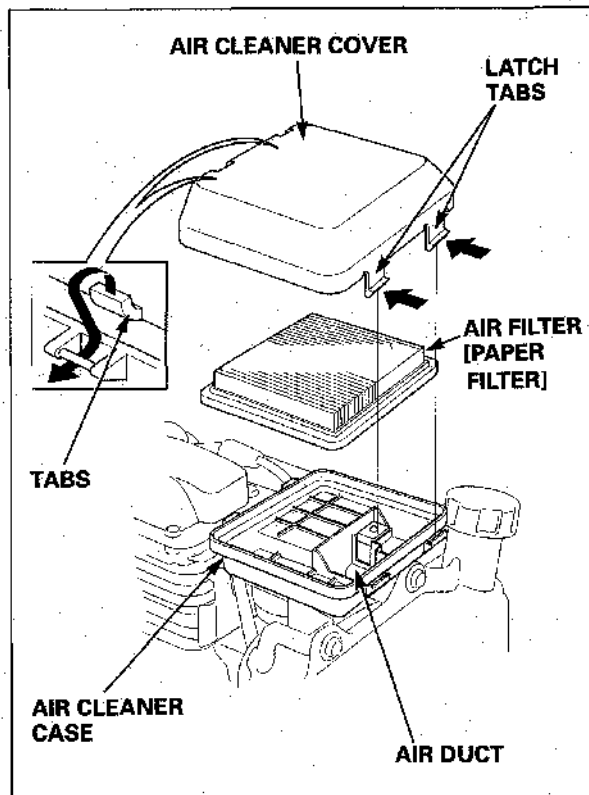

SPARK PLUG

Inspection/Cleaning:

Standard spark plug

- 1) Clean any dirt from around the spark plug.
- 2) Remove the plug cap, and use a spark plug wrench to remove the plug.

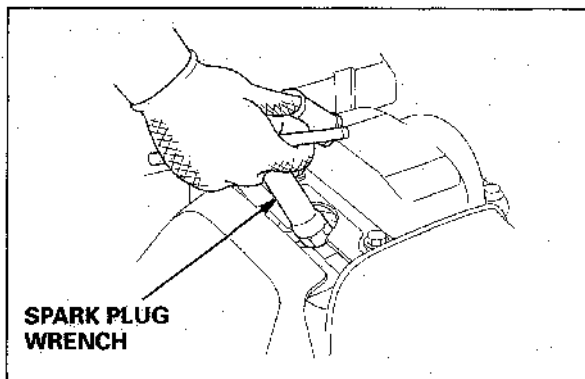

- 3) Visually inspect the spark plug. Discard the plug if the insulator is cracked or chipped.
- 4) Remove carbon or other deposits with a stiff wire brush.
- 5) Measure the plug gap with a wire-type feeler gauge.

Spark plug gap

If necessary, adjust the gap by bending the side electrode.

- 6) Make sure the sealing washer is in good condition; replace the plug if necessary.
- 7) Install the plug fingertight to seat the washer, then tighten with a plug wrench (an additional 1/2 turn if a new plug) to compress the sealing washer. If you are reusing a plug, tighten 1/8–1/4 turn after the plug seats.

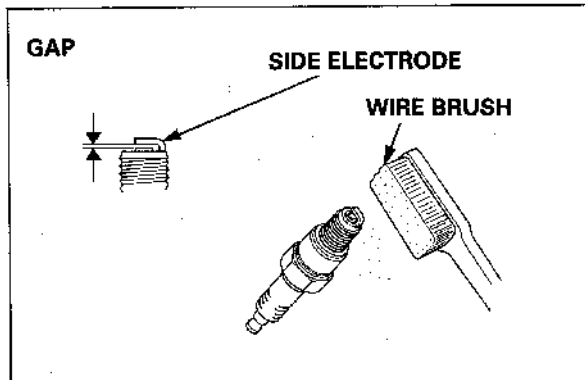

CAUTION:

A loose spark plug can become very hot and can damage the engine. Overtightening the spark plug can damage the threads in the cylinder barrel.

VALVE CLEARANCE

Inspection/Adjustment:

NOTE:

Valve clearance inspection and adjustment must be performed with the engine cold.

- 1) Remove the four 6 x 12 mm flange bolts.
- 2) When removing the cylinder head cover, pry off slowly at each corner of the head cover.

CAUTION:

- Do not remove the cylinder head cover with force. It can deform the cylinder head cover.
- Replace the cylinder head cover if it is deformed.

- 3) Set the piston at top dead center of the compression stroke (both valves fully closed).

Top dead center of the compression stroke is in the position where the cylinder head cover mating surface is in line with the cam pulley alignment marks.

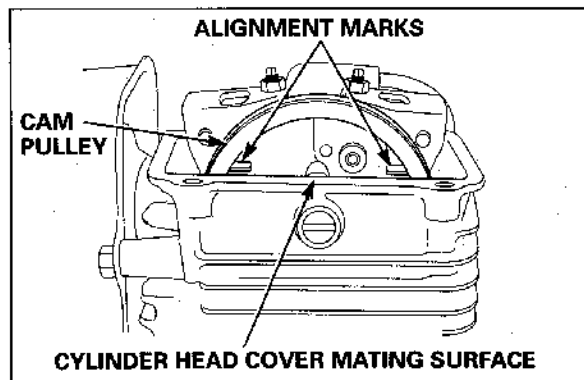
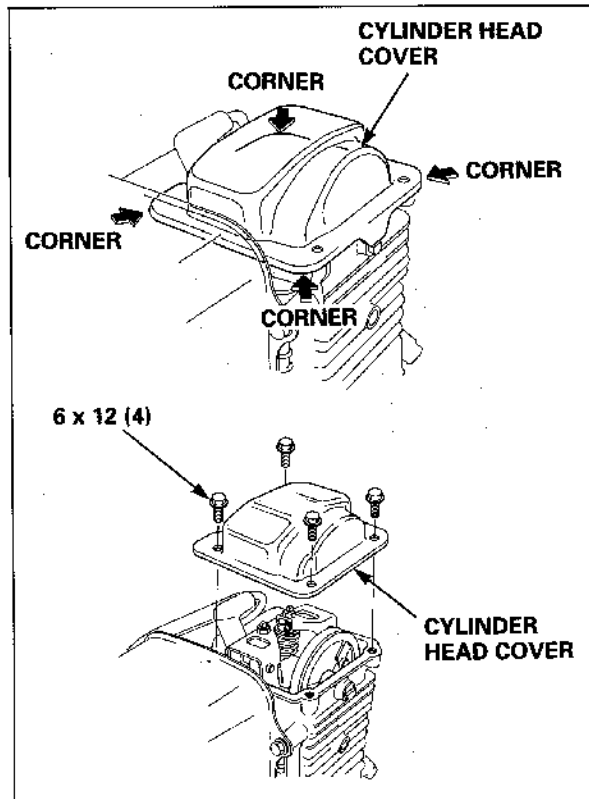

- 4) Insert a feeler gauge between the valve stem and the adjusting screw on the rocker arm.

Standard valve
clearance

- 5) If adjustment is necessary, proceed as follows:
- Hold the adjusting screw using the special tool, and loosen the lock nut.
 - Turn the adjusting screw to obtain the specified intake and exhaust valve clearance.
 - Hold the adjusting screw using the special tool, and tighten the lock nut.

TORQUE

- 6) Recheck valve clearance after tightening the lock nut.
- 7) Apply a liquid packing (Three Bond 1207 Honda Bond #4 or equivalent) to the cylinder head cover installation surface, and install the cylinder head cover

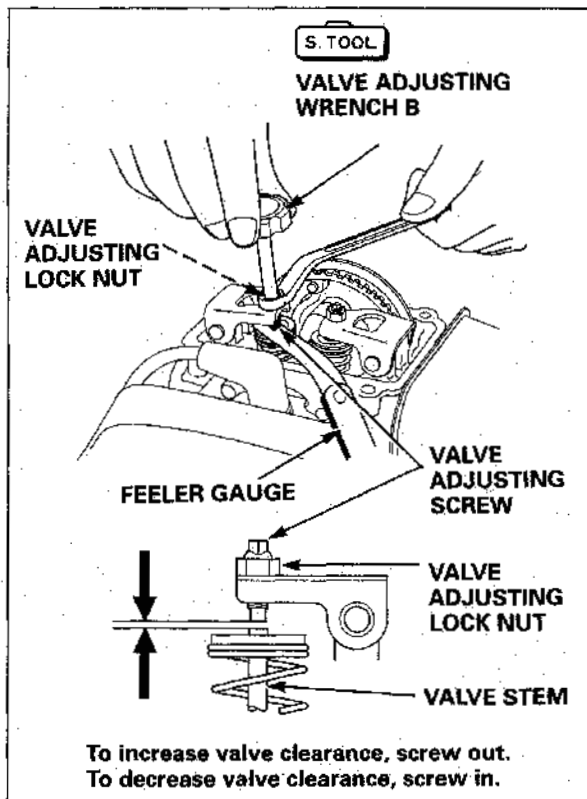

CARBURETOR

Pilot screw:

The pilot screw is fitted with a limiter cap that prevents excessive enrichment of the air-fuel mixture in order to comply with emissions regulations.

Do not attempt to remove the limiter cap for pilot screw adjustment. The limiter cap cannot be removed without breaking the pilot screw.

Pilot screw adjustment must be performed only when it is disassembled

Throttle stop screw:

- 1) Start the engine and allow it to warm up to normal operating temperature.
- 2) With the engine idling, turn the throttle stop screw to obtain the standard idle speed.

Standard idle speed

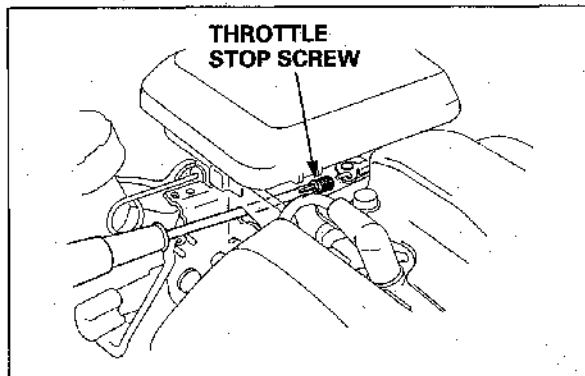
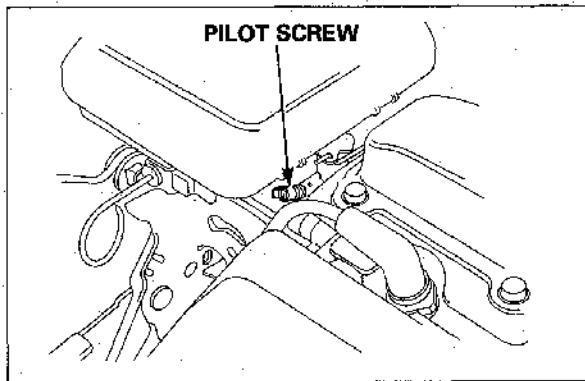

GOVERNOR

Adjustment:

- 1) Remove the fuel tank.
- 2) Move the control lever to the **FAST** position.
- 3) Loosen the governor arm nut on the governor arm.
- 4) Pushing the governor arm toward the carburetor side, open the carburetor throttle valve fully.
- 5) Holding the carburetor throttle valve fully open, turn the governor arm shaft clockwise fully, and tighten the governor arm nut to the specified torque.

TORQUE

- 6) Move the control lever to the **SLOW** position.
- 7) With the control lever in the **SLOW** position, check to see whether the carburetor throttle valve is fully closed.
- 8) Check to see whether the governor arm and the carburetor throttle valve operate smoothly.
- 9) Start the engine and warm it up to the normal operating temperature. Move the control lever to the maximum engine speed position, and check the maximum engine speed.

Maximum speed (no load)

- 10) Adjustment is made at the governor spring installation position of the control lever.

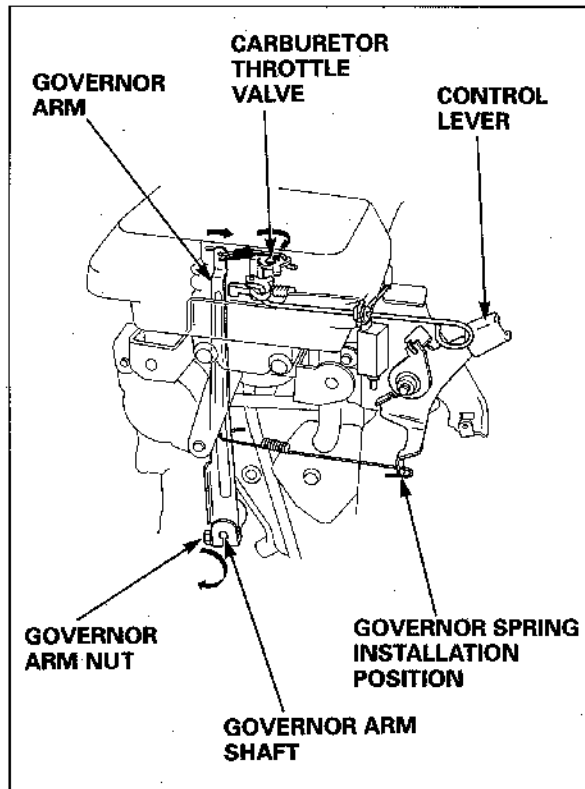

FUEL TANK/FUEL STRAINER

Cleaning:

⚠ WARNING

**Gasoline is highly flammable and explosive.
You can be burned or seriously injured when handling fuel.**

- **Keep heat, sparks, and flame away.**
- **Handle fuel only outdoors.**
- **Wipe up spills immediately.**

- 1) Drain the fuel into a suitable container, and remove the fuel tank.

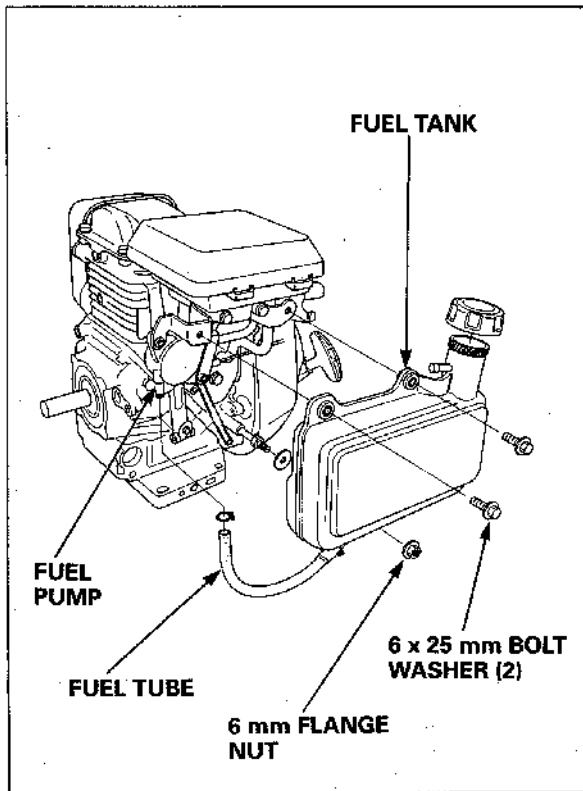

- 2) Disconnect the fuel line, and unscrew the fuel strainer from the tank.
- 3) Clean the strainer with solvent, and check to be sure the strainer screen is undamaged.
- 4) Insert the fuel strainer in the fuel tank. Connect the fuel tube to the fuel tank.
- 5) Install the fuel tank.
- 6) After assembly, check for fuel leaks.

FUEL LINE

Check:

⚠ WARNING

Gasoline is highly flammable and explosive. You can be burned or seriously injured when handling fuel.

- Keep heat, sparks, and flame away.
- Handle fuel only outdoors.
- Wipe up spills immediately.

- 1) Check the fuel lines for deterioration, cracks or signs of leakage.
- 2) Check the fuel pump for dirt and other foreign material.
- 3) Drain the fuel into a suitable container.
- 4) Replace the fuel lines and fuel pump as necessary.

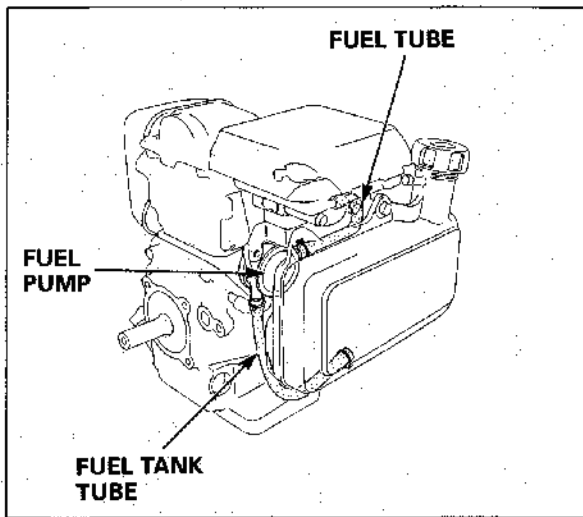
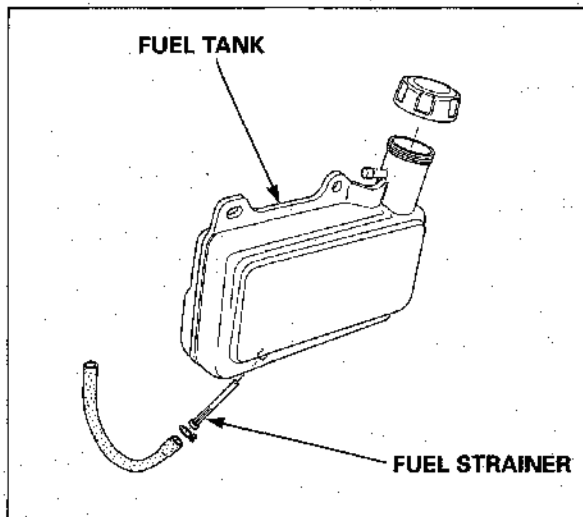

SPARK ARRESTER (OPTIONAL PART)

Cleaning:

⚠ WARNING

The muffler becomes very hot during operation and remains hot for a while after stopping the engine. Be careful not to touch the muffler while it is hot. Allow it to cool before proceeding.

CAUTION:

The spark arrester must be serviced every 100 hours to maintain its efficiency.

- 1) Remove the three 6 x 12 mm flange bolts from the muffler protector, and remove the muffler protector.
- 2) Remove the 4 x 6 mm tapping screw from the spark arrester, and remove the spark arrester from the muffler.
- 3) Check for carbon deposits around the exhaust port and spark arrester. Clean, if necessary, with a wire brush.
- 4) Replace the spark arrester if there are any breaks or tears.
- 5) Install the spark arrester and muffler protector in the reverse order of removal.

