

GXE2.0H

Horizontal shaft electric motor (integrated type)

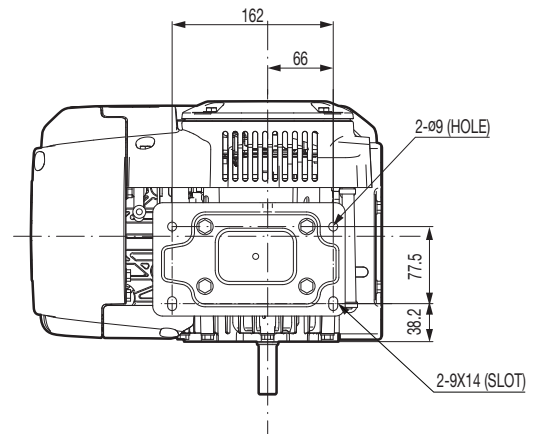

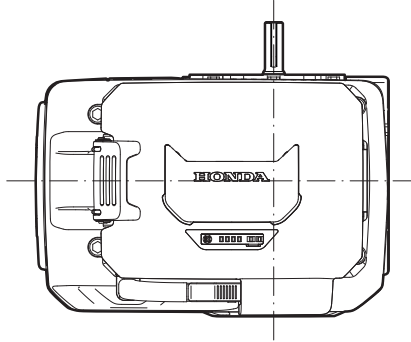
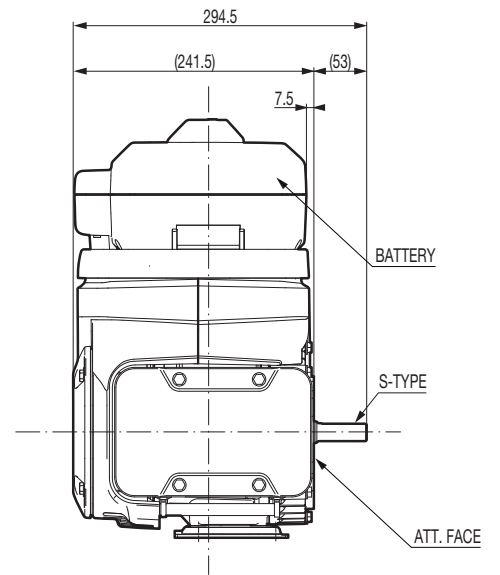
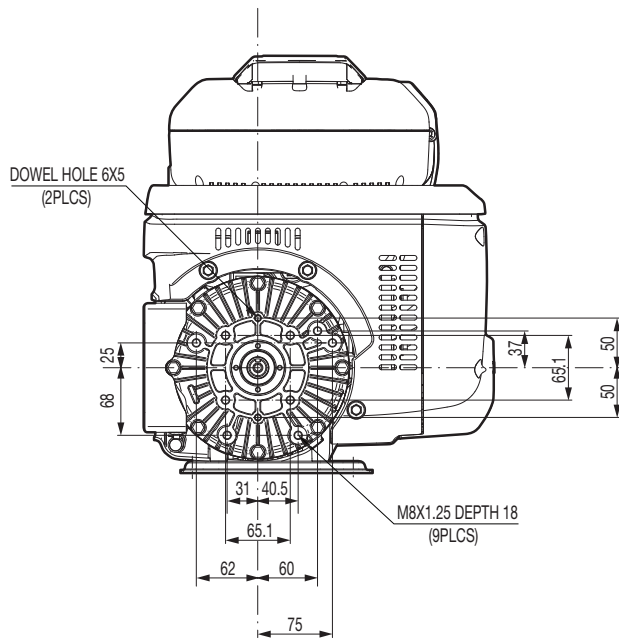
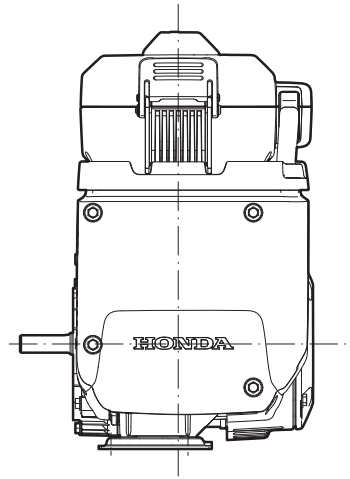
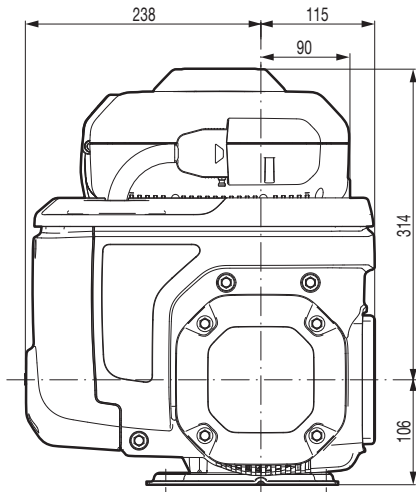

PTO SHAFT DIMENSIONS

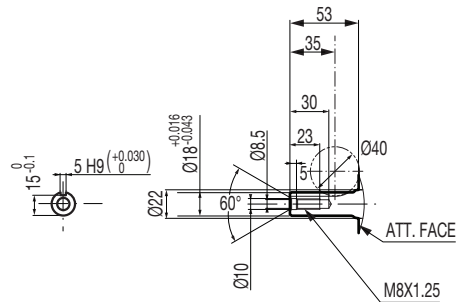

S-TYPE

Q-TYPE

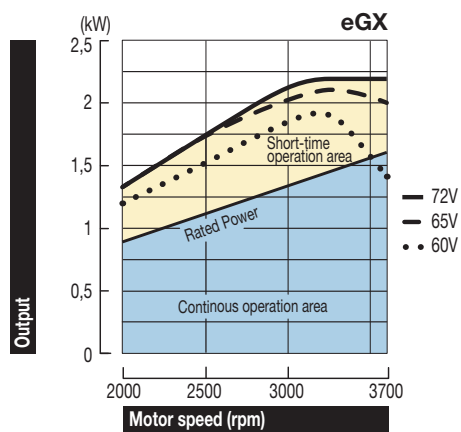
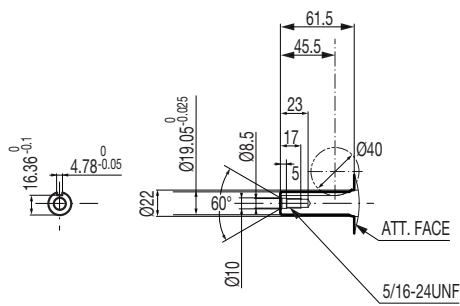

Specifications

Model	GXE2.0H
Motor type	Three phase brushless DC forced air cooling permanent magnet
Net power	1.8 kW (2.4 HP) / 3 600 rpm
Cont. rated power	1.6 kW (2.1 HP) / 3 600 rpm
Max. net torque	4.8 Nm / 0.49 kgfm / 3 600 rpm
Controller	PWM 3 phase
Control current	27 A / 72 V
Compatible battery	DP72104Z
Compatible charger	CV7285Z
Dimensions (L x W x H)	294 x 353 x 296 mm w/o battery 294 x 353 x 420 mm with battery
Weight	19.7 kg w/o battery 26.1 kg with battery

Spezifikationen

Modell	GXE2.0H
Motortyp	Dreiphasiger bürstenloser Gleichstrommotor Permanentmagnet mit Zwangskühlung
Netto-Leistung	1.8 kW (2.4 HP) / 3 600 min ⁻¹
Max. Dauerleistung	1.6 kW (2.1 HP) / 3 600 min ⁻¹
Max. Netto-Drehmoment	4.8 Nm / 0.49 kgfm / 3 600 min ⁻¹
Regler	PWM 3 Phasen
Reglerstrom	27 A / 72 V
Zugehörige Batterie	DP72104Z
Zugehöriges Ladegerät	CV7285Z
Maße (L x B x H)	294 x 353 x 296 mm ohne Batterie 294 x 353 x 420 mm mit Batterie
Gewicht	19.7 kg ohne Batterie 26.1 kg mit Batterie

Specificaties

Model	GXE2.0H
Motortype	Driefazige, borstelloze, DC motor met permanente magneten en geforceerde luchtkoeling
Netto vermogen	1,8 kW (2,4 HP) / 3 600 tr/min
Continu nominaal vermogen	1,6 kW (2,1 HP) / 3 600 tr/min
Max. netto koppel	4,8 Nm / 0,49 kgfm / 3 600 tr/min
Sturing	PWM 3 fasig
Controlebereik	27 A / 72 V
Bijhorende batterij	DP72104Z
Bijhorende lader	CV7285Z
Afmetingen (L x B x H)	294 x 353 x 296 mm excl. batterij 294 x 353 x 420 mm incl. batterij
Gewicht	19,7 kg excl. batterij 26,1 kg incl. batterij

Spécifications techniques

Modèle	GXE2.0H
Type du moteur	A courant continu, sans balais, triphasé et aimant permanente à refroidissement par air forcé
Puissance nette	1,8 kW (2,4 HP) / 3 600 rpm
Puissance en service continu	1,6 kW (2,1 HP) / 3 600 rpm
Couple maximum net	4,8 Nm / 0,49 kgfm / 3 600 rpm
Contrôleur	PWM 3 phases
Courant régulé	27 A / 72 V
Batterie compatible	DP72104Z
Chargeur compatible	CV7285Z
Dimensions (L x L x H)	294 x 353 x 296 mm sans batterie 294 x 353 x 420 mm avec batterie
Poids	19,7 kg sans batterie 26,1 kg avec batterie

Dati tecnici

Tipo	GXE2.0H
Tipo di motore	Motore elettrico DC brushless trifase magneti permanenti con raffreddamento ad aria forzata
Potenza netta	1.8 kW (2.4 HP) / 3 600 giri/min
Potenza nominale continua	1.6 kW (2.1 HP) / 3 600 giri/min
Coppia massima	4.8 Nm / 0.49 kgfm / 3 600 giri/min
Modulo di controllo	PWM 3 phase
Corrente	27 A / 72 V
Tipo di batteria compatibile	DP72104Z
Tipo di caricabatteria compatibile	CV7285Z
Dimensioni (Lu x La x A)	294 x 353 x 296 mm senza batteria 294 x 353 x 420 mm con batteria
Peso	19.7 kg senza batteria 26.1 kg con batteria

Specifikationer

Modell	GXE2.0H
Motortyp	Trefas borstlös DC - tvingad luftkylning permanent magnet
Netto effekt	1,8 kW (2,4 HP) / 3 600 varv/minut
Rek. kontinuerlig effekt	1,6 kW (2,1 HP) / 3 600 varv/minut
Max. netto vridmoment	4,8 Nm / 0,49 kgfm / 3 600 varv/minut
Fas	PWM 3 fas
Batteri kapacitet	27 A / 72 V
Kompatibelt batteri	DP72104Z
Kompatibel laddare	CV7285Z
Dimensioner (L x B x H)	294 x 353 x 296 mm utan batteri 294 x 353 x 420 mm med batteri
Vikt	19,7 kg utan batteri 26,1 kg med batteri

HONDA

Honda Motor Europe Logistics NV

Langerbruggestraat 104
B-9000 Gent
TEL: + 32 (0)9 250 12 11

www.honda-engines-eu.com

Honda Engines – France

Honda Motor Europe Ltd Succursale France • Parc d'Activités de Pariest • Allée du 1^{er} Mai, BP 46 • Croissy Beaubourg F-77312 Marne-la-Vallée Cedex 2 • TEL: + 33 (0)1 60 37 32 45

Honda Engines – Germany

Honda Deutschland Ndl. der HME Ltd. • Hanauer Landstraße 222-224 • D-60314 Frankfurt
TEL: + 49 69 8309-365

Honda Engines – Italy

Honda Motor Europe Logistics NV • Via Maestri del Lavoro 1 • I - 37068 Vigasio (VR)
TEL: + 39 045 6173341

Honda Engines – Sweden

Honda Motor Europe Ltd Filial Sverige • Box 31002 • SE-200 49 Malmö
TEL: + 46 40 38 07 18

Honda Engines – United Kingdom

Honda Motor Europe Logistics NV • Viscount Way, South Marston Park • Swindon SN3 4TN, UK
TEL: + 44 (0) 1455 559429

All specifications are subject to change without notice.
Les caractéristiques techniques peuvent être modifiées à tout moment et sans préavis.
Spécifikationerna kan ändras utan föregående meddelande.

Le specifiche sono soggette a cambiamento senza preavviso.
Die Spezifikationen können ohne Vorankündigung geändert werden.
Alle technische specificaties kunnen op elk ogenblik en zonder kennisgeving gewijzigd worden.

HMEL - TS eGX - Sept. 2023 - Printed in Belgium

jotta.com